



**Stainless Steel Grooved Fittings  
& Press Fittings**

# PRODUCT CATALOG

2025

# Company Profile



## SINCE 2003: A COMMITMENT TO COMPLETE CUSTOMER SATISFACTION

In the ever-evolving world of construction management, there are always new and innovative companies that come to market to safely reduce project costs and reduce lead time. From day one, GroovJoint LLC has aimed to make this become a reality in the stainless steel piping industry. Founded on core values to deliver a combination of product value, quality, customer service, and innovation, GroovJoint continues to follow this philosophy for customer success.

Our global sales office is headquartered in Chicago, Illinois. Our Midwestern United States production and warehouse teams are made up of hard-working men and women who take pride in the quality product we provide. We also rely on many other domestic manufacturing companies throughout the continental US for their quality raw materials and services.

Since our beginning in 2003, we have experienced constant year over year growth. This is a testament to not only the quality of the product we provide, but also the quality of our people who interact with and serve our customers on a daily basis. We have also prioritized the continual search to ensure we can produce our quality product in the most lean and equitable way in order to compete and grow on the global scale.

With over 100 years of experience in the piping industry, our management team has a deep knowledge base on the product we offer. Since we only work with stainless steel, it has allowed us to become experts on the product. We leverage our expertise to constantly evaluate our performance and investigate new ways to improve through collaboration with our suppliers.

GroovJoint and our employees believe in these four principles:

1. Service. Our primary mission is to serve the customer.
2. Quality. We refuse to offer anything less than the best.
3. Value. All of our offerings must remain competitively priced.
4. Knowledge. Continual improvement to stay on the cutting edge.

These principles are the foundation of our company and are what our customers can rely on to complete their projects on time and under budget.



Company Profile  
 Approvals and Certifications  
 Gasket Recommendations  
 Stainless Steel Couplings  
 Stainless Steel Grooved Fittings  
 Fabrication

Page 1  
 Page 4  
 Page 5  
 Pages 6-15  
 Pages 16-37  
 Page 38

Schedule 40 Stainless Steel Fittings  
 Grooved Pipe Specifications  
 PressJoint Stainless Steel Press  
 Style Fittings  
 Data Sheets; Terms & Conditions  
 of Sale

Page 39  
 Pages 40-41  
 Pages 42-58  
 Page 59

# Stainless Steel Grooved System

**Model 24**  
 Pages 6-7  
 Rigid Coupling

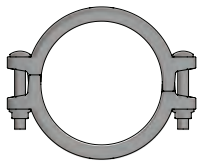

**Model 15**  
 Pages 8-9  
 Flexible Coupling



**Model 15X**  
 Pages 10-11  
 Heavy-Duty  
 Flexible Coupling

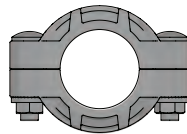

**Model GT**  
 Pages 12-13  
 Galvanized Ductile  
 Iron Rigid Coupling

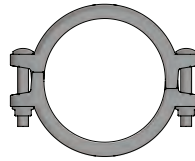

**Model 76DU**  
 Pages 14-15  
 Duplex Heavy-Duty  
 Flexible Coupling

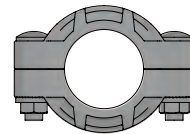

**Model 469**  
 Page 17  
 90° Elbow



**Model 464**  
 Page 18  
 45° Elbow

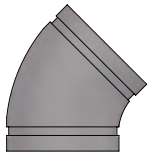

**Model 46T**  
 Page 19  
 Tee



**Model 46RT**  
 Pages 20-21  
 Reducing Tee



**Model 46RTS**  
 Page 22  
 Reducing Tee  
 Groove x Press



**Model 46RTST**  
 Page 23  
 Reducing Tee  
 Groove x MNPT



**Model 46C**  
 Pages 24-25  
 Concentric  
 Reducer

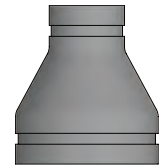

**Model 46CS**  
 Page 26  
 Concentric Reducer  
 Groove x Press

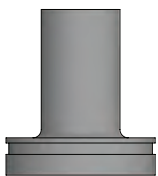

**Model 46CMT**  
 Page 27  
 Concentric Reducer  
 Groove x MNPT



**Model 46E**  
 Pages 28-29  
 Eccentric Reducer

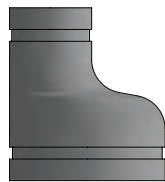

**Model 461**  
 Page 30  
 11.25° Elbow

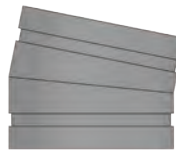

**Model 462**  
 Page 31  
 22.5° Elbow



**Model 46CAP**  
 Page 32  
 Cap

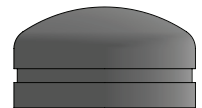

**Model 46LAT**  
 Page 33  
 45° Lateral

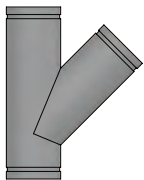

**Model 46LAT**  
 Page 34  
 45° Reducing  
 Lateral

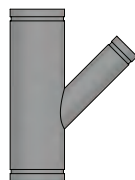

**Model 46F**  
 Page 35  
 Flange Adaptor

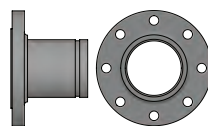

**Model 46FC**  
 Page 36  
 Cast Flange  
 Adaptor

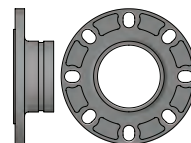

**Model BFSVB02**  
 Page 37  
 Butterfly Valve



# Stainless Steel Press System

**PJECOUP**

Page 44  
Press Coupling



**PJESCOUP**

Page 44  
Press Slip Coupling



**PJE90**

Page 45  
Press 90° Elbow



**PJE90M**

Page 45  
Press 90° Street Elbow



**PJE45**

Page 46  
Press 45° Elbow



**PJE45M**

Page 46  
Press 45° Street Elbow



**PJET**

Page 47  
Press Tee



**PJET REDUCING**

Page 48  
Press Reducing Tee



**PJEFT**

Page 49  
Press Reducing Tee FPT Branch



**PJEFP**

Page 50  
Press Reducer



**PJEVLV**

Page 51  
Press Ball Valve



**PJEFA**

Page 52  
Press Female Adaptor



**PJEMA**

Page 53  
Press Male Adaptor



**PJEF**

Page 54  
Press Flange



**PJEP**

Page 54  
Press Cap



**PJEU**

Page 55  
Press Union



**PJEVF**

Page 55  
Press Van Stone Flange



**PJEWAW**

Page 56  
Press Weld Adaptor



# Approvals and Certifications

GroovJoint fittings undergo rigorous testing before going to market. All fittings must pass dimensional and chemical analysis prior to shipping.



**ISO 14001:2015 Environmental Management System**  
**ISO 9001:2015 Quality Management System**

## Industry & Government Standards & Approvals

<b>ANSI</b>	American National Standards Institute
<b>AWWA</b>	American Water Works Association: C 606
<b>FM</b>	Factory Mutual Engineering Corp.
<b>IAPMO</b>	International Association of Plumbing & Mechanical Officials
<b>NSF</b>	NSF International
<b>UL</b>	Underwriter's Laboratories, Inc.
<b>ULC</b>	Underwriter's Laboratories of Canada

# Gasket Recommendations

GroovJoint coupling gaskets are available in many grades of materials and gasket styles. The two most common styles are the C style and E style of gasket. These are pictured below.

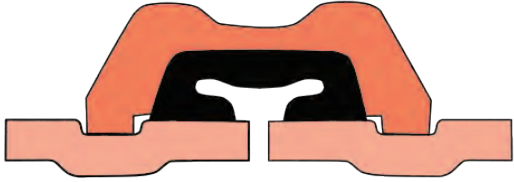

"C" style gasket

## "C" Style

The most widely used gaskets when working with grooved couplings and fittings. All GroovJoint grooved couplings come standard with the "C" style gasket installed.

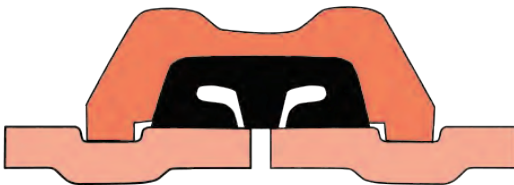

"E" style gasket

## "E" Style (Flush Seal)

Commonly called flush seal, these are primarily used for vacuum service. The inner lip of the gasket helps reduce the possibility of the gasket cavity filling up with debris and/or the distortion of the gasket in vacuum service.

## GroovJoint Rubber Gaskets

### EPDM Grade "E" (green stripe)

- Temperature range -30°F to +230°F/-34°C to +110°C
- Recommended for hot/cold water service, it can also be used with a wide variety of dilute acids, oil-free air and many chemical services.
- IAPMO classified in accordance with ANSI/NSF 61 for potable water service from +86F to +180°F/+30°C to +82°C.
- Not recommended for petroleum or steam service.

### Nitrile Grade (Buna, NBR) "T" (orange stripe)

- Temperature range -20°F to +180°F /-29°C to +82°C
- Recommended for petroleum products, air with oil vapors, vegetable oils and mineral oils.
- Not recommended for hot water services over +150°F/+66°C or for hot dry air over +140°F/+60°C.

### Fluoroelastomer Grade (Viton, FKM) "O" (blue stripe)

- Temperature range +20°F to +300°F/-7°C to +149°C
- Recommended for oxidizing acids, petroleum oil products, hydrocarbons, hydraulic fluids and air with hydrocarbons.

# Stainless Steel Rigid Coupling

## Model 24

GroovJoint Model #24 couplings are made from ASTM A743/A743M cast stainless steel (316 Stainless Steel).

Can be used on Schedule 10 or Schedule 40 grooved pipe.

Domestic options are available.

### Maximum Working Pressure:

1-1/2"–12" Sch.10 stainless steel grooved pipe 300 psi (21 bar)

1-1/2"–12" Sch. 40 stainless steel grooved pipe 600 psi (41 bar)

14" & 16" Sch.10/40 stainless steel grooved pipe 300 psi (21 bar)

### Stainless Steel Housing

316L SS, ASTM A743/A743M

### Stainless Steel Bolts

304 SS Trac bolts conforming to ASTM A193 B-8

316 SS Bolts available upon request

### Stainless Steel Nuts

304 SS heavy-duty washer nuts conforming to ASTM A194 B8, molybdenum disulfide coated

316 SS nuts available upon request



## Gaskets

### EPDM Grade "E" (green stripe)

- Temperature range -30°F to +230°F/-34°C to +110°C
- Recommended for hot/cold water service, it can also be used with a wide variety of dilute acids, oil-free air and many chemical services.
- IAPMO classified in accordance with ANSI/NSF 61 for potable water service from +86°F to +180°F/+30°C to +82°C.
- Not recommended for petroleum or steam service.

### Nitrile Grade (Buna, NBR) "T" (orange stripe)

- Temperature range -20°F to +180°F /-29°C to +82°C
- Recommended for petroleum products, air with oil vapors, vegetable oils and mineral oils.
- Not recommended for hot water services over +150°F/+66°C or for hot dry air over +140°F/+60°C.

### Fluorelastomer Grade (Viton, FKM) "O" (blue stripe)

- Temperature range +20°F to +300°F/-7°C to +149°C
- Recommended for oxidizing acids, petroleum oil products, hydrocarbons, hydraulic fluids and air with hydrocarbons.



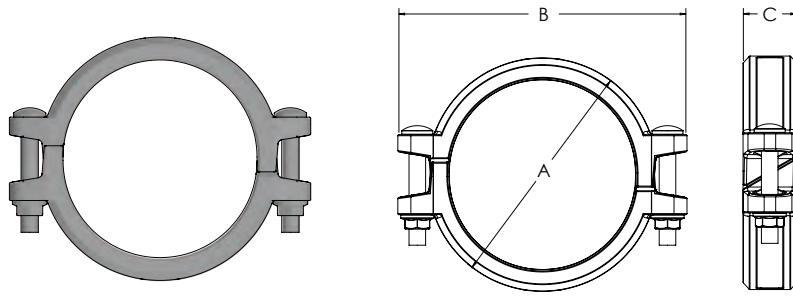

Pipe Size		Nominal Dimensions			Max. † Pressures psi bar	Bolt Size in	Weight lbs kg
Nominal in DN/mm	O.D. in mm	A in mm	B in mm	C in mm			
<b>1-1/2</b> 40	<b>1.900</b> 48	<b>2.83</b> 72	<b>4.29</b> 109	<b>1.81</b> 46	<b>600</b> 41	<b>3/8</b>	<b>1.6</b> 0.7
<b>2</b> 50	<b>2.375</b> 60	<b>3.41</b> 86	<b>5.12</b> 130	<b>1.88</b> 47	<b>600</b> 41	<b>3/8</b>	<b>2.4</b> 1.1
<b>2-1/2</b> 65	<b>2.875</b> 73	<b>3.91</b> 99	<b>5.63</b> 143	<b>1.88</b> 47	<b>600</b> 41	<b>3/8</b>	<b>2.6</b> 1.2
<b>3</b> 80	<b>3.500</b> 88	<b>4.63</b> 117	<b>6.25</b> 158	<b>1.88</b> 47	<b>600</b> 41	<b>3/8</b>	<b>3.0</b> 1.4
<b>4</b> 100	<b>4.500</b> 114	<b>5.81</b> 147	<b>7.50</b> 190	<b>1.97</b> 50	<b>600</b> 41	<b>1/2</b>	<b>4.8</b> 2.2
<b>5</b> 125	<b>5.563</b> 141	<b>7.09</b> 180	<b>9.71</b> 246	<b>2.04</b> 51	<b>600</b> 41	<b>5/8</b>	<b>6.6</b> 3.0
<b>6</b> 150	<b>6.625</b> 168	<b>8.09</b> 205	<b>10.53</b> 267	<b>2.13</b> 54	<b>600</b> 41	<b>5/8</b>	<b>7.6</b> 3.4
<b>8</b> 200	<b>8.625</b> 219	<b>10.56</b> 268	<b>13.56</b> 344	<b>2.62</b> 66	<b>600</b> 41	<b>3/4</b>	<b>16.0</b> 7.3
<b>10</b> 250	<b>10.750</b> 273	<b>12.84</b> 326	<b>16.41</b> 416	<b>2.62</b> 66	<b>600</b> 41	<b>7/8</b>	<b>22.2</b> 10.1
<b>12</b> 300	<b>12.750</b> 323	<b>15.41</b> 391	<b>18.84</b> 478	<b>2.62</b> 66	<b>600</b> 41	<b>7/8</b>	<b>30.2</b> 13.7
<b>14</b> 350	<b>14.000</b> 355	<b>16.00</b> 406	<b>19.37</b> 492	<b>2.75</b> 69	<b>300</b> 21	<b>7/8</b>	<b>28.0</b> 12.7
<b>16</b> 400	<b>16.000</b> 406	<b>18.00</b> 457	<b>21.50</b> 546	<b>2.88</b> 73	<b>300</b> 21	<b>7/8</b>	<b>30.0</b> 13.6



# Stainless Steel Flexible Coupling

## Model 15

GroovJoint Model #15 couplings are made from ASTM A743/A743M cast stainless steel (316 Stainless Steel). Can be used on Schedule 10 or Schedule 40 grooved pipe.

Domestic options are available.

### Maximum Working Pressure:

1"-12" Sch.10 stainless steel grooved pipe 300 psi (21 bar)

1"-12" Sch. 40 stainless steel grooved pipe 600 psi (41 bar)

### Stainless Steel Housing

316L SS, ASTM A743/A743M

### Stainless Steel Bolts

304 SS Trac bolts conforming to ASTM A193 B-8

316 SS Bolts available upon request

### Stainless Steel Nuts

304 SS heavy-duty washer nuts conforming to ASTM A194 B8, molybdenum disulfide coated

316 SS nuts available upon request



## Gaskets

### EPDM Grade "E" (green stripe)

- Temperature range -30°F to +230°F/-34°C to +110°C
- Recommended for hot/cold water service, it can also be used with a wide variety of dilute acids, oil-free air and many chemical services.
- IAPMO classified in accordance with ANSI/NSF 61 for potable water service from +86°F to +180°F/+30°C to +82°C.
- Not recommended for petroleum or steam service.

### Nitrile Grade (Buna, NBR) "T" (orange stripe)

- Temperature range -20°F to +180°F /-29°C to +82°C
- Recommended for petroleum products, air with oil vapors, vegetable oils and mineral oils.
- Not recommended for hot water services over +150°F/+66°C or for hot dry air over +140°F/+60°C.

### Fluorelastomer Grade (Viton, FKM) "O" (blue stripe)

- Temperature range +20°F to +300°F/-7°C to +149°C
- Recommended for oxidizing acids, petroleum oil products, hydrocarbons, hydraulic fluids and air with hydrocarbons.



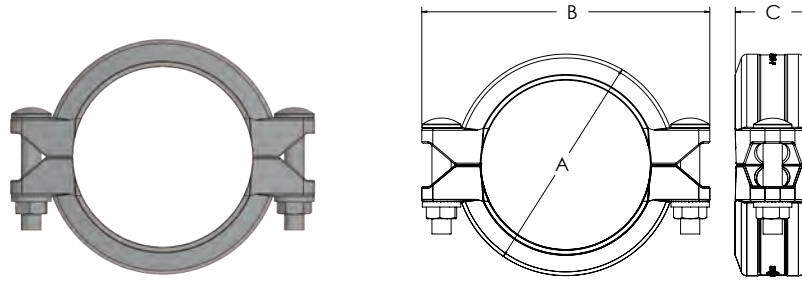

Pipe Size		Nominal Dimensions			Max. Working Pressure psi bar	Axial Displacement* in	Deflection Degree ° - ft	Bolt Size in	Weight lbs kg
Nominal Size in DN/mm	O.D. in mm	A in mm	B in mm	C in mm					
<b>1</b> 25	<b>1.310</b> 33	<b>2.19</b> 56	<b>3.45</b> 88	<b>1.73</b> 44	<b>600</b> 41	<b>0 - 0.06</b>	<b>2° - 45'</b>	<b>3/8</b>	<b>0.8</b> 0.4
<b>1-1/4</b> 32	<b>1.660</b> 42	<b>2.54</b> 65	<b>3.85</b> 98	<b>1.73</b> 44	<b>600</b> 35	<b>0 - 0.06</b>	<b>2° - 10'</b>	<b>3/8</b>	<b>1.0</b> 0.5
<b>1-1/2</b> 40	<b>1.900</b> 48	<b>2.79</b> 71	<b>4.14</b> 105	<b>1.73</b> 44	<b>600</b> 41	<b>0 - 0.06</b>	<b>1° - 54'</b>	<b>3/8</b>	<b>1.2</b> 0.5
<b>2</b> 50	<b>2.370</b> 60	<b>3.28</b> 83	<b>4.88</b> 124	<b>1.73</b> 44	<b>600</b> 41	<b>0 - 0.06</b>	<b>1° - 31'</b>	<b>3/8</b>	<b>1.6</b> 0.7
<b>2-1/2</b> 65	<b>2.870</b> 73	<b>3.88</b> 98	<b>5.55</b> 141	<b>1.73</b> 45	<b>600</b> 41	<b>0 - 0.06</b>	<b>1° - 15'</b>	<b>3/8</b>	<b>2.2</b> 1.0
<b>3</b> 80	<b>3.500</b> 89	<b>4.39</b> 111	<b>6.18</b> 157	<b>1.73</b> 44	<b>600</b> 41	<b>0 - 0.06</b>	<b>1° - 2'</b>	<b>3/8</b>	<b>2.6</b> 1.2
<b>4</b> 100	<b>4.500</b> 114	<b>5.62</b> 143	<b>7.87</b> 200	<b>1.97</b> 50	<b>600</b> 41	<b>0 - 0.13</b>	<b>1° - 36'</b>	<b>1/2</b>	<b>4.4</b> 2.0
<b>6</b> 150	<b>6.620</b> 168	<b>7.80</b> 198	<b>9.96</b> 253	<b>2.09</b> 53	<b>600</b> 41	<b>0 - 0.13</b>	<b>1° - 05'</b>	<b>5/8</b>	<b>7.4</b> 3.4
<b>8</b> 200	<b>8.620</b> 219	<b>10.04</b> 255	<b>13.27</b> 337	<b>2.44</b> 62	<b>600</b> 41	<b>0 - 0.13</b>	<b>0° - 50'</b>	<b>3/4</b>	<b>14.2</b> 6.4
<b>10</b> 250	<b>10.750</b> 273	<b>13.22</b> 336	<b>15.82</b> 402	<b>2.44</b> 62	<b>600</b> 41	<b>0 - 0.13</b>	<b>0° - 45'</b>	<b>7/8</b>	<b>18.4</b> 8.3
<b>12</b> 300	<b>12.750</b> 324	<b>15.52</b> 394	<b>17.68</b> 449	<b>2.44</b> 62	<b>600</b> 41	<b>0 - 0.13</b>	<b>0° - 37'</b>	<b>7/8</b>	<b>34.2</b> 15.2

\*Figures are maximums for rolled grooved. Standard cut groove may double these values. For design, values should be reduced by 50% up to 3" and 25% for 4" and greater.

# Stainless Steel Heavy-Duty Flexible Coupling

## Model 15X

GroovJoint Model #15 couplings are made from ASTM A743/A743M cast stainless steel (316 Stainless Steel). Can be used on Schedule 10 or Schedule 40 grooved pipe.

Domestic options are available.

### Maximum Working Pressure:

1-1/2"–12" Sch.10 stainless steel grooved pipe 300 psi (21 bar)

1-1/2"–12" Sch. 40 stainless steel grooved pipe 1000 psi (69 bar)

### Stainless Steel Housing

316L SS, ASTM A743/A743M

### Stainless Steel Bolts

304 SS Trac bolts conforming to ASTM A193 B-8

316 SS Bolts available upon request

### Stainless Steel Nuts

304 SS heavy-duty washer nuts conforming to ASTM A194 B8, molybdenum disulfide coated

316 SS nuts available upon request



## Gaskets

### EPDM Grade "E" (green stripe)

- Temperature range -30°F to +230°F/-34°C to +110°C
- Recommended for hot/cold water service, it can also be used with a wide variety of dilute acids, oil-free air and many chemical services.
- IAPMO classified in accordance with ANSI/NSF 61 for potable water service from +86°F to +180°F/+30°C to +82°C.
- Not recommended for petroleum or steam service.

### Nitrile Grade (Buna, NBR) "T" (orange stripe)

- Temperature range -20°F to +180°F /-29°C to +82°C
- Recommended for petroleum products, air with oil vapors, vegetable oils and mineral oils.
- Not recommended for hot water services over +150°F/+66°C or for hot dry air over +140°F/+60°C.

### Fluorelastomer Grade (Viton, FKM) "O" (blue stripe)

- Temperature range +20°F to +300°F/-7°C to +149°C
- Recommended for oxidizing acids, petroleum oil products, hydrocarbons, hydraulic fluids and air with hydrocarbons.



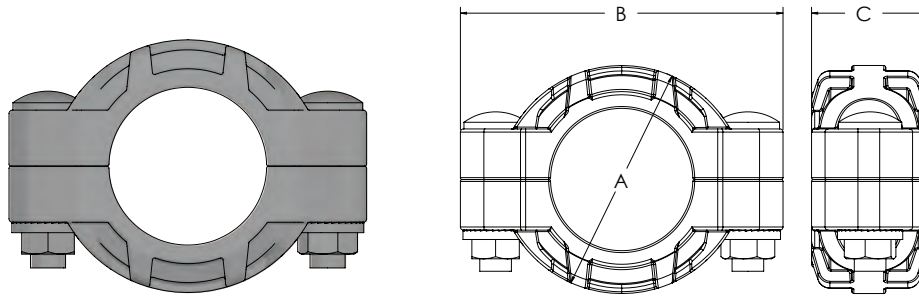

Pipe Size		Nominal Dimensions			Max. Working Pressure psi bar	Axial Displacement* in	Deflection Degree ° - ft	Bolt Size in	Weight lbs kg
Nominal Size in DN/mm	O.D. in mm	A in mm	B in mm	C in mm					
<b>1-1/2</b> 40	<b>1.900</b> 48	<b>3.02</b> 76.7	<b>4.66</b> 118.4	<b>1.83</b> 46.5	<b>1000</b> 69	<b>0 - 0.06</b>	<b>1° - 56'</b>	<b>1/2</b>	<b>2.4</b> 1.1
<b>2</b> 50	<b>2.370</b> 60	<b>3.60</b> 91.6	<b>5.10</b> 129.5	<b>1.81</b> 46.0	<b>1000</b> 69	<b>0 - 0.06</b>	<b>1° - 31'</b>	<b>1/2</b>	<b>2.8</b> 1.3
<b>2-1/2</b> 65	<b>2.870</b> 73	<b>4.25</b> 108.0	<b>4.74</b> 120.4	<b>1.83</b> 46.5	<b>1000</b> 69	<b>0 - 0.06</b>	<b>1° - 15'</b>	<b>1/2</b>	<b>3.6</b> 1.6
<b>3</b> 80	<b>3.500</b> 89	<b>4.89</b> 124.4	<b>6.56</b> 166.7	<b>1.84</b> 46.8	<b>1000</b> 69	<b>0 - 0.06</b>	<b>1° - 2'</b>	<b>1/2</b>	<b>4.4</b> 2.0
<b>4</b> 100	<b>4.500</b> 114	<b>6.10</b> 155.1	<b>8.16</b> 207.5	<b>1.98</b> 50.4	<b>1000</b> 69	<b>0 - 0.13</b>	<b>1° - 36'</b>	<b>5/8</b>	<b>6.8</b> 3.1
<b>6</b> 150	<b>6.620</b> 168	<b>8.58</b> 218	<b>10.94</b> 278	<b>2.04</b> 52	<b>1000</b> 69	<b>0 - 0.13</b>	<b>1° - 12'</b>	<b>3/4</b>	<b>11.6</b> 5.3
<b>8</b> 200	<b>8.620</b> 219	<b>10.82</b> 274.9	<b>13.51</b> 343.2	<b>2.39</b> 60.9	<b>1000</b> 69	<b>0 - 0.13</b>	<b>0° - 50'</b>	<b>7/8</b>	<b>20.4</b> 9.3
<b>10</b> 250	<b>10.750</b> 273	<b>13.43</b> 341.3	<b>17.12</b> 435.0	<b>2.53</b> 64.5	<b>1000</b> 69	<b>0 - 0.13</b>	<b>0° - 40'</b>	<b>1</b>	<b>36.0</b> 16.3
<b>12</b> 300	<b>12.750</b> 324	<b>15.62</b> 396.9	<b>19.43</b> 493.7	<b>2.53</b> 64.5	<b>1000</b> 69	<b>0 - 0.13</b>	<b>0° - 34'</b>	<b>1</b>	<b>42.4</b> 19.2

\*Figures are maximums for rolled grooved. Standard cut groove may double these values. For design, values should be reduced by 50% up to 3" and 25% for 4" and greater.

# Galvanized Ductile Iron Rigid Coupling

## Ducco GT 4020

GroovJoint Model #GT4020 couplings are manufactured by DUCCO industries, sold by GroovJoint. Can be used on Schedule 10 or Schedule 40 grooved pipe.

### Maximum Working Pressure:

- 1"–12" Sch.10 stainless steel grooved pipe 300 psi (21 bar)
- 1"–6" Sch. 40 stainless steel grooved pipe 750 psi (52 bar)
- 8"–12" Sch. 40 stainless steel grooved pipe 600 psi (41 bar)
- UL/ULC/FM Listed
- 1"–12" Sch.10/40 stainless steel grooved pipe 300 psi (21 bar)

### Ductile Iron Housing

ASTM A-536 Grade 65-45-12

### Coating

Hot dipped zinc galvanization

### Bolts

ASTM A183 Zinc plating oval neck track-head bolts  
316 SS Bolts available upon request

### Nuts

ASTM A183 Heavy hexagon nuts  
316 SS nuts available upon request



### Gaskets

#### EPDM Grade "E" (green stripe)

- Temperature range -30°F to +230°F/-34°C to +110°C
- Recommended for hot/cold water service, it can also be used with a wide variety of dilute acids, oil-free air and many chemical services.
- IAPMO classified in accordance with ANSI/NSF 61 for potable water service from +86°F to +180°F/+30°C to +82°C.
- Not recommended for petroleum or steam service.

#### Nitrile Grade (Buna, NBR) "T" (orange stripe)

- Temperature range -20°F to +180°F /-29°C to +82°C
- Recommended for petroleum products, air with oil vapors, vegetable oils and mineral oils.
- Not recommended for hot water services over +150°F/+66°C or for hot dry air over +140°F/+60°C.

#### Fluorelastomer Grade (Viton, FKM) "O" (blue stripe)

- Temperature range +20°F to +300°F/-7°C to +149°C
- Recommended for oxidizing acids, petroleum oil products, hydrocarbons, hydraulic fluids and air with hydrocarbons.



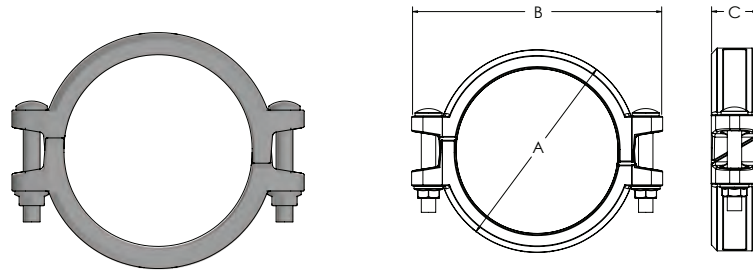

Pipe Size		Nominal Dimensions			Max. † Pressure psi	Bolt Size metric	Weight lbs kg
Size in mm	O.D. in mm	A in mm	B in mm	C in mm			
<b>1</b> 25	<b>1.310</b> 33	<b>2.17</b> 55	<b>3.86</b> 98	<b>1.77</b> 45	<b>750</b> 52	<b>M10</b>	<b>0.8</b> 0.4
<b>1-1/4</b> 32	<b>1.660</b> 42	<b>2.36</b> 60	<b>4.21</b> 107	<b>1.77</b> 45	<b>750</b> 52	<b>M10</b>	<b>1.0</b> 0.5
<b>1-1/2</b> 40	<b>1.900</b> 48	<b>2.80</b> 71	<b>4.49</b> 114	<b>1.77</b> 45	<b>750</b> 52	<b>M10</b>	<b>1.2</b> 0.5
<b>2</b> 50	<b>2.375</b> 60	<b>3.35</b> 85	<b>5.04</b> 128	<b>1.77</b> 45	<b>750</b> 52	<b>M10</b>	<b>1.4</b> 0.6
<b>2-1/2</b> 65	<b>2.875</b> 73	<b>3.94</b> 100	<b>5.79</b> 147	<b>1.89</b> 48	<b>750</b> 52	<b>M10</b>	<b>1.8</b> 0.8
<b>3</b> 80	<b>3.500</b> 88	<b>4.45</b> 113	<b>6.34</b> 161	<b>1.89</b> 48	<b>750</b> 52	<b>M10</b>	<b>2.2</b> 1.0
<b>4</b> 100	<b>4.500</b> 114	<b>5.63</b> 143	<b>7.68</b> 195	<b>2.09</b> 53	<b>750</b> 52	<b>M10</b>	<b>3.0</b> 1.4
<b>5</b> 125	<b>5.563</b> 141	<b>6.77</b> 172	<b>9.06</b> 230	<b>2.09</b> 53	<b>750</b> 52	<b>M12</b>	<b>4.6</b> 2.1
<b>6</b> 150	<b>6.625</b> 168	<b>7.87</b> 200	<b>10.43</b> 265	<b>2.13</b> 54	<b>750</b> 52	<b>M12</b>	<b>5.6</b> 2.5
<b>8</b> 200	<b>8.625</b> 219	<b>10.24</b> 260	<b>13.94</b> 354	<b>2.32</b> 59	<b>600</b> 41	<b>M20</b>	<b>11.6</b> 5.3
<b>10</b> 250	<b>10.750</b> 273	<b>12.40</b> 315	<b>15.98</b> 406	<b>2.48</b> 63	<b>600</b> 41	<b>M20</b>	<b>14.8</b> 6.7
<b>12</b> 300	<b>12.750</b> 323	<b>14.49</b> 368	<b>18.19</b> 462	<b>2.52</b> 64	<b>600</b> 41	<b>M20</b>	<b>20.2</b> 9.2

# Duplex Heavy-Duty Flexible Coupling

## Model 76DU

GroovJoint Model #76DU couplings are made from Duplex CD3MN (2205) duplex stainless steel. Can be used on Schedule 10 or Schedule 40/80 grooved pipe.

### Maximum Cold Working Pressure (CWP):

2"–6" Sch.40 stainless steel cut grooved pipe 1200 psi (82 bar)

2"–6" Sch.80 stainless steel cut grooved pipe 1200 psi (82 bar)

### Duplex Stainless Steel Housing

Duplex CD3MN (2205)

### Stainless Steel Bolts

316 SS Bolts

### Stainless Steel Nuts

316 SS Bolts, teflon dipped



## Gaskets

### EPDM Grade "E" (green stripe)

- Temperature range -30°F to +230°F/-34°C to +110°C
- Recommended for hot/cold water service, it can also be used with a wide variety of dilute acids, oil-free air and many chemical services.
- IAPMO classified in accordance with ANSI/NSF 61 for potable water service from +86°F to +180°F/+30°C to +82°C.
- Not recommended for petroleum or steam service.

### Nitrile Grade (Buna, NBR) "T" (orange stripe)

- Temperature range -20°F to +180°F/-29°C to +82°C
- Recommended for petroleum products, air with oil vapors, vegetable oils and mineral oils.
- Not recommended for hot water services over +150°F/+66°C or for hot dry air over +140°F/+60°C.

### Fluorelastomer Grade (Viton, FKM) "O" (blue stripe)

- Temperature range +20°F to +300°F/-7°C to +149°C
- Recommended for oxidizing acids, petroleum oil products, hydrocarbons, hydraulic fluids and air with hydrocarbons.



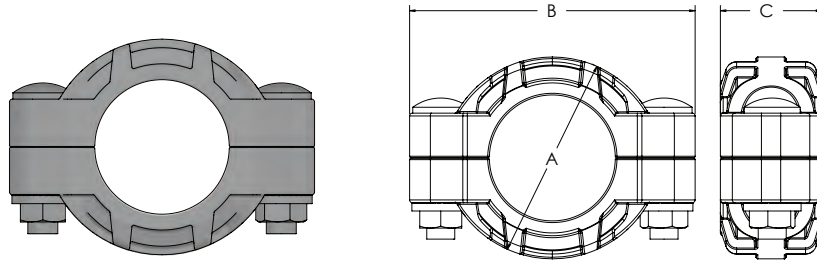

Pipe Size		Nominal Dimensions			Max. † Pressure psi bar	Deflection Degree ° - ft	Bolt Size in	Weight lbs kg
Nominal Size in DN/mm	O.D. in mm	A in mm	B in mm	C in mm				
<b>2</b> 50	<b>2.375</b> 60	<b>5.12</b> 130	<b>3.35</b> 85	<b>1.77</b> 45	<b>1200</b> 63	<b>2°-20'</b>	<b>3/8</b>	<b>2.6</b> 1.2
<b>2-1/2</b> 65	<b>2.875</b> 73	<b>5.91</b> 150	<b>3.78</b> 96	<b>1.77</b> 45	<b>1200</b> 63	<b>2°-10'</b>	<b>1/2</b>	<b>3.4</b> 1.5
<b>3</b> 80	<b>3.500</b> 89	<b>6.42</b> 163	<b>4.45</b> 113	<b>1.77</b> 45	<b>1200</b> 63	<b>1°-47'</b>	<b>1/2</b>	<b>4.0</b> 1.8
<b>4</b> 100	<b>4.500</b> 114	<b>7.95</b> 202	<b>5.67</b> 144	<b>1.97</b> 50	<b>1200</b> 63	<b>3°-0'</b>	<b>5/8</b>	<b>6.8</b> 3.1
<b>6</b> 150	<b>6.625</b> 168	<b>10.98</b> 279	<b>7.95</b> 202	<b>2.05</b> 52	<b>1200</b> 63	<b>2°-22'</b>	<b>3/4</b>	<b>12.4</b> 5.6



# Stainless Steel Grooved Fittings



## Material Specifications

### 1" - 12"

GroovJoint grooved pipe fittings are full-flow design in both 304L and 316L grades of stainless steel, conforming to ASTM A403. Products are available in both Sch. 10 and Sch. 40 wall thicknesses. Sch. 40 fittings can be roll grooved or cut grooved.

### 14" - 24"

GroovJoint larger diameter fittings are manufactured (A403WPW/A774, A403CR, A774/ASTM774) and are available in both 304L and 316L grades and Sch. 10 and Sch. 40 wall thicknesses.

## Pressure Rating

GroovJoint Fittings are rated to the pressure of the lowest rated component of the system, please see GroovJoint Couplings pages for pressure ratings.

GroovJoint Stainless Steel Grooved Pipe Fittings are designed to reduce labor costs in the field by using the grooved method for the installation of piping systems.

## Approvals



## GroovJoint Product Codes

469, 464, 46T, 46RT, 46RTS, 46RTST, 46C, 46CMT, 46CS, 46E, 46CAP

\*461, 462, 46F, 46FC, 46LAT (Not UL Listed Fittings)

## Product Code Detail

**469**

Product code

**4**

Grade

**60**

Pipe Diameter

**40\***

Thickness  
(If REQ)

**D\***

Domestic  
(If REQ)

# Stainless Steel 90° Elbow

Model 469

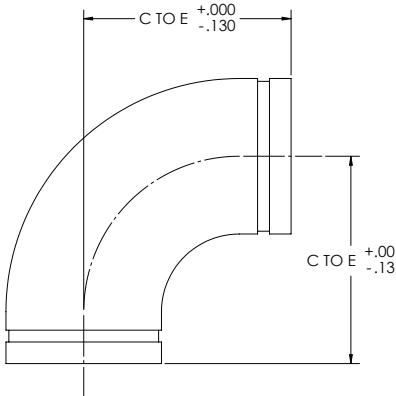

Pipe Size		C to E in mm	Weight lbs kg
Nominal in mm	O.D. in mm		
<b>1</b> 25	<b>1.315</b> 33	<b>2.88</b> 73	<b>0.6</b> 0.3
<b>1-1/4</b> 32	<b>1.660</b> 42	<b>3.13</b> 80	<b>0.8</b> 0.4
<b>1-1/2</b> 40	<b>1.900</b> 48	<b>3.50</b> 89	<b>1.2</b> 0.5
<b>2</b> 50	<b>2.375</b> 60	<b>4.50</b> 114	<b>1.8</b> 0.8
<b>2-1/2</b> 65	<b>2.875</b> 73	<b>5.00</b> 127	<b>2.6</b> 1.2
<b>3</b> 80	<b>3.500</b> 88	<b>4.50</b> 114	<b>3.2</b> 1.5
<b>4</b> 100	<b>4.500</b> 114	<b>6.00</b> 152	<b>4.4</b> 2.0
<b>5</b> 125	<b>5.563</b> 141	<b>7.50</b> 191	<b>7.8</b> 3.5
<b>6</b> 150	<b>6.625</b> 168	<b>9.00</b> 229	<b>11.4</b> 5.2
<b>8</b> 200	<b>8.625</b> 219	<b>12.00</b> 305	<b>21.8</b> 9.9
<b>10</b> 250	<b>10.750</b> 273	<b>15.00</b> 381	<b>37.8</b> 17.1
<b>12</b> 300	<b>12.750</b> 324	<b>18.00</b> 457	<b>57.6</b> 26.1
<b>14</b> 355	<b>14.000</b> 355	<b>21.00</b> 533	<b>80.0</b> 36.3
<b>16</b> 406	<b>16.000</b> 406	<b>24.00</b> 609	<b>104.0</b> 47.2
<b>18</b> 457	<b>18.000</b> 457	<b>27.00</b> 685	<b>125.0</b> 56.7
<b>20</b> 508	<b>20.000</b> 508	<b>30.00</b> 762	<b>180.0</b> 81.6
<b>24</b> 609	<b>24.000</b> 609	<b>36.00</b> 914	<b>305.0</b> 138.3

Schedule 10 dimensions (Schedule 40 dimensions may vary)  
Domestic options available

**MAXIMUM WORKING PRESSURE** – See specific data sheet for rating of coupling in use.

# Stainless Steel 45° Elbow

Model 464

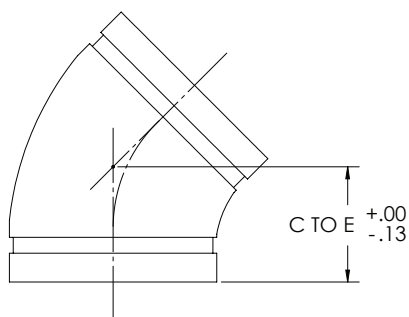
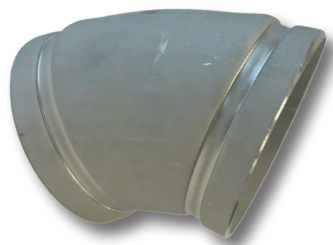

Pipe Size		C to E in mm	Weight lbs kg
Nominal in mm	O.D. in mm		
<b>1</b>	<b>1.315</b>	<b>2.00</b>	<b>0.4</b>
25	33	51	0.2
<b>1-1/4</b>	<b>1.660</b>	<b>2.00</b>	<b>0.6</b>
32	42	51	0.3
<b>1-1/2</b>	<b>1.900</b>	<b>2.25</b>	<b>0.8</b>
40	48	89	0.4
<b>2</b>	<b>2.375</b>	<b>2.75</b>	<b>1.4</b>
50	60	70	0.6
<b>2-1/2</b>	<b>2.875</b>	<b>2.81</b>	<b>1.6</b>
65	73	71	0.7
<b>3</b>	<b>3.500</b>	<b>2.00</b>	<b>1.8</b>
80	89	51	0.8
<b>4</b>	<b>4.500</b>	<b>2.50</b>	<b>2.2</b>
100	114	64	1.0
<b>5</b>	<b>5.563</b>	<b>3.13</b>	<b>3.8</b>
125	141	79	1.7
<b>6</b>	<b>6.625</b>	<b>3.75</b>	<b>5.6</b>
150	168	95	2.5
<b>8</b>	<b>8.625</b>	<b>5.00</b>	<b>12.2</b>
200	219	127	5.5
<b>10</b>	<b>10.750</b>	<b>6.25</b>	<b>19.0</b>
250	273	159	8.6
<b>12</b>	<b>12.750</b>	<b>7.50</b>	<b>29.6</b>
300	324	191	13.4
<b>14</b>	<b>14.000</b>	<b>8.80</b>	<b>40.0</b>
355	355	223	18.1
<b>16</b>	<b>16.000</b>	<b>10.00</b>	<b>52.0</b>
406	406	254	23.6
<b>18</b>	<b>18.000</b>	<b>11.30</b>	<b>67.0</b>
457	457	287	30.4
<b>20</b>	<b>20.000</b>	<b>12.50</b>	<b>95.0</b>
508	508	317	43.1
<b>24</b>	<b>24.000</b>	<b>15.00</b>	<b>158.0</b>
609	609	381	71.7

Schedule 10 dimensions (Schedule 40 dimensions may vary)  
Domestic options available



MAXIMUM WORKING PRESSURE – See specific data sheet for rating of coupling in use.

# Stainless Steel Tee

Model 46T

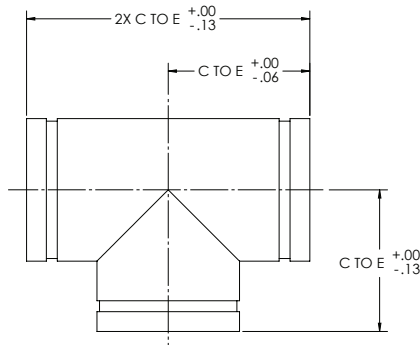

Pipe Size		C to E in mm	Weight lbs kg
Nominal in mm	O.D. in mm		
<b>1</b>	<b>1.315</b>	<b>2.88</b>	<b>0.8</b>
25	33	73	0.4
<b>1-1/4</b>	<b>1.660</b>	<b>3.38</b>	<b>1.4</b>
32	42	86	0.6
<b>1-1/2</b>	<b>1.900</b>	<b>3.38</b>	<b>1.6</b>
40	48	86	0.7
<b>2</b>	<b>2.375</b>	<b>2.75</b>	<b>1.8</b>
50	60	70	0.8
<b>2-1/2</b>	<b>2.875</b>	<b>3.07</b>	<b>2.2</b>
65	73	78	1.0
<b>3</b>	<b>3.500</b>	<b>3.77</b>	<b>4.0</b>
80	89	96	1.8
<b>4</b>	<b>4.500</b>	<b>4.47</b>	<b>5.2</b>
100	114	114	2.4
<b>5</b>	<b>5.563</b>	<b>5.91</b>	<b>8.6</b>
125	141	150	3.9
<b>6</b>	<b>6.625</b>	<b>5.91</b>	<b>11.8</b>
150	168	150	5.4
<b>8</b>	<b>8.625</b>	<b>7.79</b>	<b>21.6</b>
200	219	198	9.8
<b>10</b>	<b>10.750</b>	<b>8.89</b>	<b>36</b>
250	273	226	16.3
<b>12</b>	<b>12.750</b>	<b>10.39</b>	<b>53.0</b>
300	324	264	24.0
<b>14</b>	<b>14.000</b>	<b>11.00</b>	<b>64.0</b>
355	355	279	29.0
<b>16</b>	<b>16.000</b>	<b>12.00</b>	<b>74.8</b>
406	406	300	33.9
<b>18</b>	<b>18.000</b>	<b>14.00</b>	<b>97.6</b>
457	457	355	44.3
<b>20</b>	<b>20.000</b>	<b>15.00</b>	<b>133.4</b>
508	508	381	60.5
<b>24</b>	<b>24.000</b>	<b>22.00</b>	<b>285.0</b>
609	609	558	129.3

Schedule 10 dimensions (Schedule 40 dimensions may vary)  
Domestic options available



**MAXIMUM WORKING PRESSURE** – See specific data sheet for rating of coupling in use.

# Stainless Steel Reducing Tee

Model 46RT

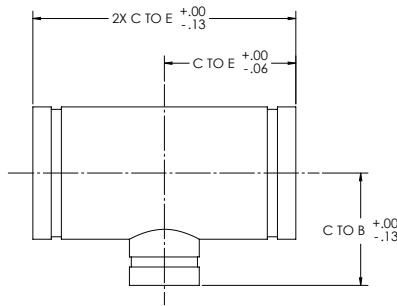

Pipe Size		C to E in mm	C to B in mm	Weight lbs kg
Nominal in mm	O.D. in mm			
1-1/2 x 1-1/2 x 1 40 x 40 x 25	1.900 x 1.900 x 1.315 48 x 48 x 33	2.75 86	2.75 86	1.2 0.5
1-1/2 x 1-1/2 x 1-1/4 40 x 40 x 25	1.900 x 1.900 x 1.660 48 x 48 x 42	2.75 86	2.75 86	1.2 0.5
2 x 2 x 1 50 x 50 x 25	2.375 x 2.375 x 1.315 60 x 60 x 33	3.25 83	3.25 70	1.8 0.8
2 x 2 x 1-1/4 50 x 50 x 32	2.375 x 2.375 x 1.660 60 x 60 x 42	3.25 83	3.25 83	1.8 0.8
2 x 2 x 1-1/2 50 x 50 x 40	2.375 x 2.375 x 1.900 60 x 60 x 48	2.75 70	2.75 70	1.8 0.8
2-1/2 x 2-1/2 x 1 65 x 65 x 25	2.875 x 2.875 x 1.315 73 x 73 x 33	3.75 95	3.75 95	2.4 1.1
2-1/2 x 2-1/2 x 1-1/2 65 x 65 x 40	2.875 x 2.875 x 1.900 73 x 73 x 48	3.75 95	3.75 95	2.4 1.1
2-1/2 x 2-1/2 x 2 65 x 65 x 50	2.875 x 2.875 x 2.375 73 x 73 x 60	3.07 78	3.07 78	2.4 1.1
3 x 3 x 1 80 x 80 x 25	3.500 x 3.500 x 1.315 89 x 89 x 33	4.25 108	4.25 108	3.0 1.4
3 x 3 x 1-1/4 80 x 80 x 32	3.500 x 3.500 x 1.660 89 x 89 x 42	4.25 108	4.25 108	3.0 1.4
3 x 3 x 1-1/2 80 x 80 x 40	3.500 x 3.500 x 1.900 89 x 89 x 48	4.25 108	4.25 108	3.0 1.4
3 x 3 x 2 80 x 80 x 50	3.500 x 3.500 x 2.375 89 x 89 x 60	3.77 96	3.77 82	3.0 1.4
3 x 3 x 2-1/2 80 x 80 x 65	3.500 x 3.500 x 2.875 89 x 89 x 73	3.77 96	3.77 82	3.0 1.4
4 x 4 x 2 100 x 100 x 50	4.500 x 4.500 x 2.375 114 x 114 x 60	4.47 114	3.82 97	4.2 1.9
4 x 4 x 2-1/2 100 x 100 x 65	4.500 x 4.500 x 2.875 114 x 114 x 73	4.47 114	4.47 114	4.2 1.9
4 x 4 x 3 100 x 100 x 80	4.500 x 4.500 x 3.500 114 x 114 x 89	4.47 115	3.88 70	4.2 1.9



Schedule 10 dimensions (Schedule 40 dimensions may vary)  
Domestic options available

MAXIMUM WORKING PRESSURE – See specific data sheet for rating of coupling in use.

# Stainless Steel Reducing Tee

Model 46RT

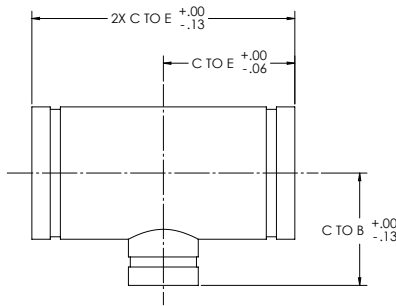

Nominal in mm	Pipe Size		C to E in mm	C to B in mm	Weight lbs kg
		O.D. in mm			
<b>6 x 6 x 1-1/2</b> 150 x 150 x 40	<b>6.625 x 6.625 x 1.900</b> 168 x 168 x 48	<b>5.91</b> 150	<b>5.91</b> 150	<b>9.8</b> 4.4	
<b>6 x 6 x 2</b> 150 x 150 x 50	<b>6.625 x 6.625 x 2.375</b> 168 x 168 x 89	<b>5.91</b> 150	<b>5.91</b> 150	<b>9.8</b> 4.4	
<b>6 x 6 x 3</b> 150 x 150 x 80	<b>6.625 x 6.625 x 3.500</b> 168 x 168 x 60	<b>5.91</b> 150	<b>4.88</b> 124	<b>9.8</b> 4.4	
<b>6 x 6 x 4</b> 150 x 150 x 100	<b>6.625 x 6.625 x 4.500</b> 168 x 168 x 114	<b>5.91</b> 150	<b>5.12</b> 130	<b>9.8</b> 4.4	
<b>8 x 8 x 4</b> 200 x 200 x 100	<b>8.625 x 8.625 x 4.500</b> 219 x 219 x 114	<b>7.79</b> 198	<b>6.31</b> 160	<b>18.0</b> 8.2	
<b>8 x 8 x 6</b> 200 x 200 x 150	<b>8.625 x 8.625 x 6.625</b> 219 x 219 x 168	<b>7.79</b> 198	<b>6.62</b> 168	<b>18.0</b> 8.2	
<b>10 x 10 x 6</b> 250 x 250 x 200	<b>10.750 x 10.750 x 6.625</b> 273 x 273 x 168	<b>8.89</b> 226	<b>7.70</b> 196	<b>31.8</b> 14.4	
<b>10 x 10 x 8</b> 250 x 250 x 200	<b>10.750 x 10.750 x 8.625</b> 273 x 273 x 219	<b>8.89</b> 226	<b>8.59</b> 218	<b>31.8</b> 14.4	
<b>12 x 12 x 8</b> 300 x 300 x 200	<b>12.750 x 12.750 x 8.625</b> 34 x 34 x 219	<b>10.39</b> 264	<b>9.51</b> 242	<b>44.4</b> 20.1	
<b>12 x 12 x 10</b> 300 x 300 x 250	<b>12.750 x 12.750 x 10.750</b> 324 x 324 x 273	<b>10.39</b> 264	<b>9.89</b> 251	<b>44.4</b> 20.1	
<b>14 x 14 x 12</b> 355 x 355 x 300	<b>14.000 x 14.000 x 12.000</b> 355 x 355 x 323	<b>11.00</b> 279	<b>11.00</b> 279	<b>54.0</b> 24.5	
<b>16 x 16 x 14</b> 406 x 406 x 355	<b>16.000 x 16.000 x 14.000</b> 406 x 406 x 355	<b>12.00</b> 300	<b>12.00</b> 300	<b>65.0</b> 29.5	
<b>18 x 18 x 16</b> 457 x 457 x 406	<b>18.000 x 18.000 x 16.000</b> 457 x 457 x 406	<b>14.00</b> 355	<b>14.00</b> 355	<b>83.0</b> 37.6	
<b>20 x 20 x 18</b> 508 x 508 x 457	<b>20.000 x 20.000 x 18.000</b> 508 x 508 x 457	<b>15.00</b> 381	<b>15.00</b> 381	<b>118.0</b> 53.5	
<b>24 x 24 x 20</b> 609 x 609 x 508	<b>24.000 x 24.000 x 20.000</b> 609 x 609 x 508	<b>22.00</b> 558	<b>22.00</b> 558	<b>179.0</b> 81.2	

Schedule 10 dimensions (Schedule 40 dimensions may vary)  
Domestic options available



MAXIMUM WORKING PRESSURE – See specific data sheet for rating of coupling in use.

# Stainless Steel Reducing Tee Groove x Press

Model 46RTS

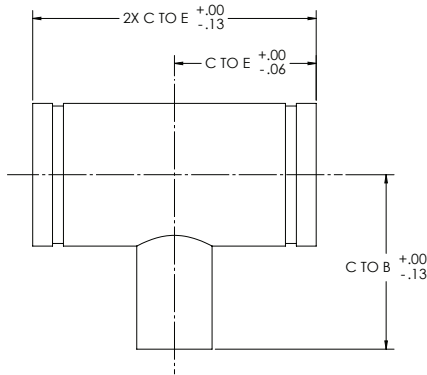

Pipe Size		C to E in mm	C to B in mm	Weight lbs kg
Nominal in mm	O.D. in mm			
<b>2-1/2 x 2-1/2 x 3/4</b> 65 x 65 x 20	<b>2.875 x 2.875 x 1.050</b> 73 x 73 x 27	<b>3.75</b> 95	<b>4.10</b> 104	<b>2.4</b> 1.1
<b>2-1/2 x 2-1/2 x 1</b> 65 x 65 x 25	<b>2.875 x 2.875 x 1.315</b> 73 x 73 x 33	<b>3.75</b> 95	<b>4.10</b> 104	<b>2.4</b> 1.1
<b>2-1/2 x 2-1/2 x 1-1/4</b> 65 x 65 x 32	<b>2.875 x 2.875 x 1.660</b> 73 x 73 x 42	<b>3.75</b> 95	<b>4.10</b> 104	<b>2.4</b> 1.1
<b>2-1/2 x 2-1/2 x 1-1/2</b> 65 x 65 x 40	<b>2.875 x 2.875 x 1.900</b> 73 x 73 x 48	<b>3.75</b> 95	<b>4.10</b> 104	<b>2.4</b> 1.1
<b>2-1/2 x 2-1/2 x 2</b> 65 x 65 x 50	<b>2.875 x 2.875 x 2.375</b> 73 x 73 x 60	<b>3.75</b> 95	<b>4.60</b> 117	<b>2.4</b> 1.1
<b>3 x 3 x 3/4</b> 80 x 80 x 20	<b>3.500 x 3.500 x 1.050</b> 89 x 89 x 27	<b>4.25</b> 108	<b>4.20</b> 107	<b>3.0</b> 1.4
<b>3 x 3 x 1</b> 80 x 80 x 25	<b>3.500 x 3.500 x 1.315</b> 89 x 89 x 33	<b>4.25</b> 108	<b>4.20</b> 107	<b>3.0</b> 1.4
<b>3 x 3 x 1-1/4</b> 80 x 80 x 32	<b>3.500 x 3.500 x 1.660</b> 89 x 89 x 42	<b>4.25</b> 108	<b>4.20</b> 107	<b>3.0</b> 1.4
<b>3 x 3 x 1-1/2</b> 80 x 80 x 40	<b>3.500 x 3.500 x 1.900</b> 89 x 89 x 48	<b>4.25</b> 108	<b>4.50</b> 114	<b>3.0</b> 1.4
<b>3 x 3 x 2</b> 80 x 80 x 50	<b>3.500 x 3.500 x 2.375</b> 89 x 89 x 60	<b>4.25</b> 108	<b>5.00</b> 127	<b>3.0</b> 1.4
<b>4 x 4 x 3/4</b> 100 x 100 x 20	<b>4.500 x 4.500 x 1.050</b> 114 x 114 x 27	<b>4.47</b> 114	<b>5.50</b> 140	<b>4.2</b> 1.9
<b>4 x 4 x 1</b> 100 x 100 x 25	<b>4.500 x 4.500 x 1.315</b> 114 x 114 x 33	<b>4.47</b> 114	<b>5.50</b> 140	<b>4.2</b> 1.9
<b>4 x 4 x 1-1/4</b> 100 x 100 x 32	<b>4.500 x 4.500 x 1.660</b> 114 x 114 x 42	<b>4.47</b> 114	<b>5.50</b> 140	<b>4.2</b> 1.9
<b>4 x 4 x 1-1/2</b> 100 x 100 x 40	<b>4.500 x 4.500 x 1.900</b> 114 x 114 x 48	<b>4.47</b> 114	<b>5.50</b> 140	<b>4.2</b> 1.9
<b>4 x 4 x 2</b> 100 x 100 x 50	<b>4.500 x 4.500 x 2.375</b> 114 x 114 x 60	<b>4.47</b> 114	<b>5.50</b> 140	<b>4.2</b> 1.9
<b>6 x 6 x 3/4</b> 150 x 150 x 20	<b>6.625 x 6.625 x 1.050</b> 168 x 168 x 27	<b>5.91</b> 150	<b>6.00</b> 152	<b>9.8</b> 4.4
<b>6 x 6 x 1</b> 150 x 150 x 25	<b>6.625 x 6.625 x 1.315</b> 168 x 168 x 33	<b>5.91</b> 150	<b>6.00</b> 152	<b>9.8</b> 4.4
<b>6 x 6 x 1-1/4</b> 150 x 150 x 32	<b>6.625 x 6.625 x 1.660</b> 168 x 168 x 42	<b>5.91</b> 150	<b>6.00</b> 152	<b>9.8</b> 4.4
<b>6 x 6 x 1-1/2</b> 150 x 150 x 40	<b>6.625 x 6.625 x 1.900</b> 168 x 168 x 48	<b>5.91</b> 150	<b>6.00</b> 152	<b>9.8</b> 4.4
<b>6 x 6 x 2</b> 150 x 150 x 50	<b>6.625 x 6.625 x 2.375</b> 168 x 168 x 60	<b>5.91</b> 150	<b>6.50</b> 165	<b>9.8</b> 4.4

Schedule 10 dimensions (Schedule 40 dimensions may vary)  
Domestic options available

MAXIMUM WORKING PRESSURE – See specific data sheet for rating of coupling in use.



# Stainless Steel Reducing Tee Groove x MNPT

Model 46RTST

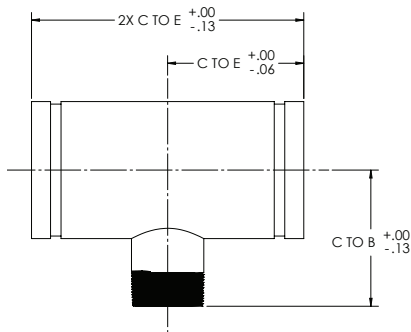

Pipe Size		C to E in mm	C to B in mm	Weight lbs kg
Nominal in mm	O.D. in mm			
<b>2-1/2 x 2-1/2 x 3/4</b> 65 x 65 x 20	<b>2.875 x 2.875 x 1.050</b> 73 x 73 x 27	<b>3.75</b> 95	<b>3.75</b> 95	<b>2.4</b> 1.1
<b>2-1/2 x 2-1/2 x 1</b> 65 x 65 x 25	<b>2.875 x 2.875 x 1.315</b> 73 x 73 x 33	<b>3.75</b> 95	<b>3.75</b> 95	<b>2.4</b> 1.1
<b>2-1/2 x 2-1/2 x 1-1/4</b> 65 x 65 x 32	<b>2.875 x 2.875 x 1.660</b> 73 x 73 x 42	<b>3.75</b> 95	<b>3.75</b> 95	<b>2.4</b> 1.1
<b>2-1/2 x 2-1/2 x 1-1/2</b> 65 x 65 x 40	<b>2.875 x 2.875 x 1.900</b> 73 x 73 x 48	<b>3.75</b> 95	<b>3.75</b> 95	<b>2.4</b> 1.1
<b>2-1/2 x 2-1/2 x 2</b> 65 x 65 x 50	<b>2.875 x 2.875 x 2.375</b> 73 x 73 x 60	<b>3.75</b> 95	<b>3.75</b> 95	<b>2.4</b> 1.1
<b>3 x 3 x 3/4</b> 80 x 80 x 20	<b>3.500 x 3.500 x 1.050</b> 89 x 89 x 27	<b>4.25</b> 108	<b>4.25</b> 108	<b>3.0</b> 1.4
<b>3 x 3 x 1</b> 80 x 80 x 25	<b>3.500 x 3.500 x 1.315</b> 89 x 89 x 33	<b>4.25</b> 108	<b>4.25</b> 108	<b>3.0</b> 1.4
<b>3 x 3 x 1-1/4</b> 80 x 80 x 32	<b>3.500 x 3.500 x 1.660</b> 89 x 89 x 42	<b>4.25</b> 108	<b>4.25</b> 108	<b>3.0</b> 1.4
<b>3 x 3 x 1-1/2</b> 80 x 80 x 40	<b>3.500 x 3.500 x 1.900</b> 89 x 89 x 48	<b>4.25</b> 108	<b>4.25</b> 108	<b>3.0</b> 1.4
<b>3 x 3 x 2</b> 80 x 80 x 50	<b>3.500 x 3.500 x 2.375</b> 89 x 89 x 60	<b>4.25</b> 108	<b>4.25</b> 108	<b>3.0</b> 1.4
<b>4 x 4 x 3/4</b> 100 x 100 x 20	<b>4.500 x 4.500 x 1.050</b> 114 x 114 x 27	<b>4.47</b> 114	<b>4.47</b> 114	<b>4.2</b> 1.9
<b>4 x 4 x 1</b> 100 x 100 x 25	<b>4.500 x 4.500 x 1.315</b> 114 x 114 x 33	<b>4.47</b> 114	<b>4.47</b> 114	<b>4.2</b> 1.9
<b>4 x 4 x 1-1/4</b> 100 x 100 x 32	<b>4.500 x 4.500 x 1.660</b> 114 x 114 x 42	<b>4.47</b> 114	<b>4.47</b> 114	<b>4.2</b> 1.9
<b>4 x 4 x 1-1/2</b> 100 x 100 x 40	<b>4.500 x 4.500 x 1.900</b> 114 x 114 x 48	<b>4.47</b> 114	<b>4.47</b> 114	<b>4.2</b> 1.9
<b>4 x 4 x 2</b> 100 x 100 x 50	<b>4.500 x 4.500 x 2.375</b> 114 x 114 x 60	<b>4.47</b> 114	<b>4.47</b> 114	<b>4.2</b> 1.9
<b>6 x 6 x 3/4</b> 150 x 150 x 20	<b>6.625 x 6.625 x 1.050</b> 168 x 168 x 27	<b>5.91</b> 150	<b>5.91</b> 150	<b>9.8</b> 4.4
<b>6 x 6 x 1</b> 150 x 150 x 25	<b>6.625 x 6.625 x 1.315</b> 168 x 168 x 33	<b>5.91</b> 150	<b>5.91</b> 150	<b>9.8</b> 4.4
<b>6 x 6 x 1-1/4</b> 150 x 150 x 32	<b>6.625 x 6.625 x 1.660</b> 168 x 168 x 42	<b>5.91</b> 150	<b>5.91</b> 150	<b>9.8</b> 4.4
<b>6 x 6 x 1-1/2</b> 150 x 150 x 40	<b>6.625 x 6.625 x 1.900</b> 168 x 168 x 48	<b>5.91</b> 150	<b>5.91</b> 150	<b>9.8</b> 4.4
<b>6 x 6 x 2</b> 150 x 150 x 50	<b>6.625 x 6.625 x 2.375</b> 168 x 168 x 60	<b>5.91</b> 150	<b>5.91</b> 150	<b>9.8</b> 4.4

Schedule 10 dimensions (Schedule 40 dimensions may vary)  
Domestic options available



MAXIMUM WORKING PRESSURE – See specific data sheet for rating of coupling in use.



# Stainless Steel Concentric Reducer

Model 46C

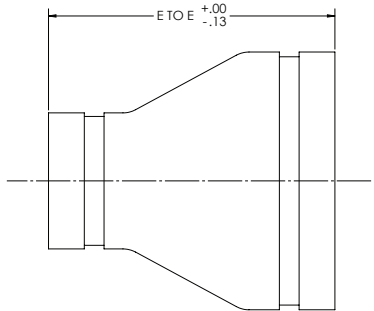

Nominal in mm	Pipe Size		E to E in mm	Weight lbs kg
	O.D. in mm			
1-1/2 x 1 40 x 25	1.900 x 1.315 48 x 34		3.75 95	0.6 0.3
1-1/2 x 1-1/4 40 x 32	1.900 x 1.660 48 x 42		3.75 95	0.6 0.3
2 x 1 50 x 25	2.375 x 1.315 60 x 33.4		3.75 95	0.8 0.4
2 x 1-1/4 50 x 32	2.375 x 1.660 60 x 42		3.75 95	0.8 0.4
2 x 1-1/2 50 x 40	2.375 x 1.900 60 x 48		5.00 127	0.8 0.4
2-1/2 x 1-1/2 65 x 40	2.875 x 1.900 73 x 48		5.00 127	1.2 0.5
2-1/2 x 2 65 x 50	2.875 x 2.375 73 x 60		5.00 127	1.2 0.5
3 x 1 80 x 25	3.500 x 1.315 89 x 34		5.00 127	1.8 0.8
3 x 1-1/4 80 x 32	3.500 x 1.660 89 x 42		5.00 127	1.8 0.8
3 x 1-1/2 80 x 40	3.500 x 1.900 89 x 48		5.00 127	1.8 0.8
3 x 2 80 x 50	3.500 x 2.375 89 x 60		5.00 127	1.8 0.8
3 x 2-1/2 80 x 65	3.500 x 2.875 88 x 73		5.00 127	1.8 0.8
4 x 2 100 x 50	4.500 x 2.375 114 x 60		5.00 127	2.4 1.1
4 x 2-1/2 100 x 65	4.500 x 2.875 114 x 73		5.00 127	2.4 1.1
4 x 3 100 x 80	4.500 x 3.500 114 x 89		5.00 127	2.4 1.1
5 x 3 125 x 80	5.563 x 3.500 141 x 89		9.00 229	3.2 1.5
5 x 4 125 x 100	5.563 x 4.500 141 x 114		9.00 229	3.2 1.5

Schedule 10 dimensions (Schedule 40 dimensions may vary)  
Domestic options available



MAXIMUM WORKING PRESSURE – See specific data sheet for rating of coupling in use.

# Stainless Steel Concentric Reducer

Model 46C

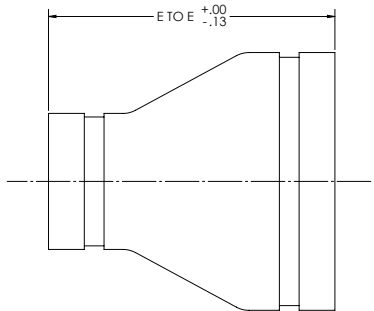

Pipe Size		E to E in mm	Weight lbs kg
Nominal in mm	O.D. in mm		
<b>6 x 2</b> 150 x 50	<b>6.625 x 2.375</b> 168 x 60	<b>5.50</b> 229	<b>4</b> 1.8
<b>6 x 2-1/2</b> 150 x 65	<b>6.625 x 2.875</b> 168 x 73	<b>5.50</b> 381	<b>4</b> 1.8
<b>6 x 3</b> 150 x 100	<b>6.625 x 3.500</b> 168 x 89	<b>5.50</b> 140	<b>4</b> 1.8
<b>6 x 4</b> 150 x 100	<b>6.625 x 4.500</b> 168 x 114	<b>5.50</b> 140	<b>4</b> 1.8
<b>6 x 5</b> 150 x 125	<b>6.625 x 5.500</b> 168 x 141	<b>5.50</b> 140	<b>4</b> 1.8
<b>8 x 4</b> 200 x 100	<b>8.625 x 4.500</b> 219 x 114	<b>6.00</b> 152	<b>6.8</b> 3.1
<b>8 x 6</b> 200 x 150	<b>8.625 x 6.626</b> 219 x 168	<b>6.00</b> 152	<b>6.8</b> 3.1
<b>10 x 4</b> 250 x 100	<b>10.750 x 4.500</b> 273 x 114	<b>7.00</b> 254	<b>10.2</b> 4.6
<b>10 x 6</b> 250 x 150	<b>10.750 x 6.625</b> 273 x 168	<b>7.00</b> 178	<b>10.2</b> 4.6
<b>10 x 8</b> 250 x 200	<b>10.750 x 8.625</b> 273 x 219	<b>7.00</b> 178	<b>10.2</b> 4.6
<b>12 x 6</b> 300 x 150	<b>12.750 x 6.625</b> 324 x 168	<b>8.00</b> 356	<b>14.4</b> 6.5
<b>12 x 8</b> 300 x 200	<b>12.750 x 8.625</b> 324 x 219	<b>8.00</b> 356	<b>16.2</b> 7.3
<b>12 x 10</b> 300 x 250	<b>12.750 x 10.750</b> 324 x 273	<b>8.00</b> 356	<b>16.2</b> 7.3
<b>14 x 12</b> 355 x 300	<b>14.000 x 12.000</b> 355 x 323	<b>17.00</b> 431	<b>39.6</b> 18.0
<b>16 x 14</b> 406 x 355	<b>16.000 x 14.000</b> 406 x 355	<b>18.00</b> 457	<b>48.6</b> 22.0
<b>18 x 16</b> 457 x 406	<b>18.000 x 16.000</b> 457 x 406	<b>19.00</b> 482	<b>57.0</b> 25.9
<b>20 x 18</b> 508 x 457	<b>20.000 x 18.000</b> 508 x 457	<b>24.00</b> 609	<b>92.8</b> 42.1
<b>24 x 20</b> 609 x 508	<b>24.000 x 20.000</b> 609 x 508	<b>24.00</b> 609	<b>124.6</b> 56.5



Schedule 10 dimensions (Schedule 40 dimensions may vary)  
Domestic options available

**MAXIMUM WORKING PRESSURE** – See specific data sheet for rating of coupling in use.

# Stainless Steel Concentric Reducer Groove x Press

Model 46CS

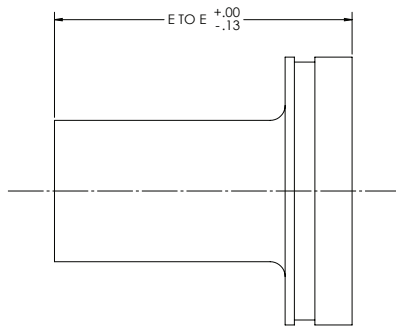

Pipe Size		E to E in mm	Weight lbs kg
Nominal in mm	O.D. in mm		
<b>2-1/2 x 3/4</b> 65 x 20	<b>2.875 x 1.050</b> 73 x 27	<b>5.00</b> 127	<b>2.0</b> 0.9
<b>2-1/2 x 1</b> 65 x 25	<b>2.875 x 1.315</b> 73 x 33	<b>5.00</b> 127	<b>2.0</b> 0.9
<b>2-1/2 x 1-1/4</b> 65 x 32	<b>2.875 x 1.660</b> 73 x 42	<b>5.00</b> 127	<b>2.0</b> 0.9
<b>2-1/2 x 1-1/2</b> 65 x 40	<b>2.875 x 1.900</b> 73 x 48	<b>5.00</b> 127	<b>2.0</b> 0.9
<b>2-1/2 x 2</b> 65 x 50	<b>2.875 x 2.375</b> 73 x 60	<b>5.00</b> 127	<b>2.0</b> 0.9
<b>3 x 3/4</b> 80 x 20	<b>3.500 x 1.050</b> 89 x 27	<b>5.00</b> 127	<b>2.8</b> 1.3
<b>3 x 1</b> 80 x 25	<b>3.500 x 1.315</b> 89 x 33	<b>5.00</b> 127	<b>2.8</b> 1.3
<b>3 x 1-1/4</b> 80 x 32	<b>3.500 x 1.660</b> 89 x 42	<b>5.00</b> 127	<b>2.8</b> 1.3
<b>3 x 1-1/2</b> 80 x 40	<b>3.500 x 1.900</b> 89 x 48	<b>5.00</b> 127	<b>2.8</b> 1.3
<b>3 x 2</b> 80 x 50	<b>3.500 x 2.375</b> 89 x 60	<b>5.00</b> 127	<b>2.8</b> 1.3
<b>4 x 3/4</b> 100 x 20	<b>4.500 x 1.050</b> 114 x 27	<b>5.00</b> 127	<b>4.8</b> 2.2
<b>4 x 1</b> 100 x 25	<b>4.500 x 1.315</b> 114 x 33	<b>5.00</b> 127	<b>4.8</b> 2.2
<b>4 x 1-1/4</b> 100 x 32	<b>4.500 x 1.660</b> 114 x 42	<b>5.00</b> 127	<b>4.8</b> 2.2
<b>4 x 1-1/2</b> 100 x 40	<b>4.500 x 1.900</b> 114 x 48	<b>5.00</b> 127	<b>4.8</b> 2.2
<b>4 x 2</b> 100 x 50	<b>4.500 x 2.375</b> 114 x 60	<b>5.00</b> 127	<b>4.8</b> 2.2
<b>6 x 3/4</b> 150 x 20	<b>6.625 x 1.050</b> 168 x 27	<b>6.00</b> 151	<b>4.0</b> 1.8
<b>6 x 1</b> 150 x 25	<b>6.625 x 1.315</b> 168 x 33	<b>6.00</b> 151	<b>4.0</b> 1.8
<b>6 x 1-1/4</b> 150 x 32	<b>6.625 x 1.660</b> 168 x 42	<b>6.00</b> 151	<b>4.0</b> 1.8
<b>6 x 1-1/2</b> 150 x 40	<b>6.625 x 1.900</b> 168 x 48	<b>6.00</b> 151	<b>4.0</b> 1.8
<b>6 x 2</b> 150 x 50	<b>6.625 x 2.375</b> 168 x 60	<b>6.00</b> 151	<b>4.0</b> 1.8

Domestic options available

MAXIMUM WORKING PRESSURE – See specific data sheet for rating of coupling in use.



# Stainless Steel Concentric Reducer Groove x MNPT

Model 46CMT

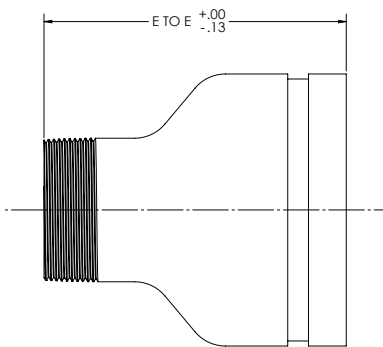
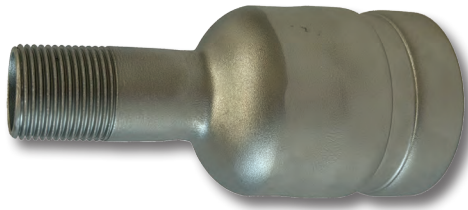

Pipe Size		E to E in mm	Weight lbs kg
Nominal in mm	O.D. in mm		
<b>2-1/2 x 3/4</b>	<b>2.875 x 1.050</b>	<b>5.00</b>	<b>1.2</b>
65 x 20	73 x 27	127	0.5
<b>2-1/2 x 1</b>	<b>2.875 x 1.315</b>	<b>5.00</b>	<b>1.2</b>
65 x 25	73 x 33	127	0.5
<b>2-1/2 x 1-1/4</b>	<b>2.875 x 1.660</b>	<b>5.00</b>	<b>1.2</b>
65 x 32	73 x 42	127	0.5
<b>2-1/2 x 1-1/2</b>	<b>2.875 x 1.900</b>	<b>5.00</b>	<b>1.2</b>
65 x 40	73 x 48	127	0.5
<b>2-1/2 x 2</b>	<b>2.875 x 2.375</b>	<b>5.00</b>	<b>1.2</b>
65 x 50	73 x 60	127	0.5
<b>3 x 3/4</b>	<b>3.500 x 1.050</b>	<b>5.00</b>	<b>1.6</b>
80 x 20	89 x 27	127	0.7
<b>3 x 1</b>	<b>3.500 x 1.315</b>	<b>5.00</b>	<b>1.6</b>
80 x 25	89 x 33	127	0.7
<b>3 x 1-1/4</b>	<b>3.500 x 1.660</b>	<b>5.00</b>	<b>1.6</b>
80 x 32	89 x 42	127	0.7
<b>3 x 1-1/2</b>	<b>3.500 x 1.900</b>	<b>5.00</b>	<b>1.6</b>
80 x 40	89 x 48	127	0.7
<b>3 x 2</b>	<b>3.500 x 2.375</b>	<b>5.00</b>	<b>1.6</b>
80 x 50	89 x 60	127	0.7
<b>4 x 3/4</b>	<b>4.500 x 1.050</b>	<b>5.00</b>	<b>2.0</b>
100 x 20	114 x 27	127	0.9
<b>4 x 1</b>	<b>4.500 x 1.315</b>	<b>5.00</b>	<b>2.0</b>
100 x 25	114 x 33	127	0.9
<b>4 x 1-1/4</b>	<b>4.500 x 1.660</b>	<b>5.00</b>	<b>2.0</b>
100 x 32	114 x 42	127	0.9
<b>4 x 1-1/2</b>	<b>4.500 x 1.900</b>	<b>5.00</b>	<b>2.0</b>
100 x 40	114 x 48	127	0.9
<b>4 x 2</b>	<b>4.500 x 2.375</b>	<b>5.00</b>	<b>2.0</b>
100 x 50	114 x 60	127	0.9
<b>6 x 3/4</b>	<b>6.625 x 1.050</b>	<b>5.00</b>	<b>3.0</b>
150 x 20	168 x 27	127	1.4
<b>6 x 1</b>	<b>6.625 x 1.315</b>	<b>5.00</b>	<b>3.0</b>
150 x 25	168 x 33	127	1.4
<b>6 x 1-1/4</b>	<b>6.625 x 1.660</b>	<b>5.00</b>	<b>3.0</b>
150 x 32	168 x 42	127	1.4
<b>6 x 1-1/2</b>	<b>6.625 x 1.900</b>	<b>5.00</b>	<b>3.0</b>
150 x 40	168 x 48	127	1.4
<b>6 x 2</b>	<b>6.625 x 2.375</b>	<b>5.00</b>	<b>3.0</b>
150 x 50	168 x 60	127	1.4



MAXIMUM WORKING PRESSURE – See specific data sheet for rating of coupling in use.

# Stainless Steel Eccentric Reducer

Model 46E

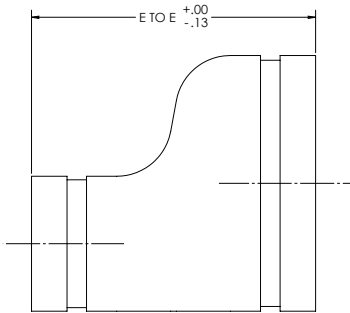

Nominal in mm	Pipe Size		E to E in mm	Weight lbs kg
	O.D. in mm			
<b>1-1/2 x 1</b> 40 x 25	<b>1.900 x 1.315</b> 48 x 34		<b>3.75</b> 95	<b>0.6</b> 0.3
<b>1-1/2 x 1-1/4</b> 40 x 32	<b>1.900 x 1.660</b> 48 x 42		<b>3.75</b> 95	<b>0.6</b> 0.3
<b>2 x 1</b> 50 x 25	<b>2.375 x 1.315</b> 60 x 34		<b>3.50</b> 95	<b>0.6</b> 0.3
<b>2 x 1-1/4</b> 50 x 32	<b>2.375 x 1.660</b> 60 x 42		<b>3.50</b> 95	<b>0.8</b> 0.4
<b>2 x 1-1/2</b> 50 x 40	<b>2.375 x 1.900</b> 60 x 48		<b>3.50</b> 95	<b>0.8</b> 0.4
<b>2-1/2 x 2</b> 65 x 50	<b>2.875 x 2.375</b> 73 x 60		<b>5.00</b> 127	<b>1.4</b> 0.6
<b>3 x 1</b> 80 x 25	<b>3.500 x 1.315</b> 89 x 34		<b>5.00</b> 127	<b>2.0</b> 0.9
<b>3 x 2</b> 80 x 50	<b>3.500 x 2.375</b> 89 x 60		<b>5.00</b> 127	<b>2.0</b> 0.9
<b>3 x 2-1/2</b> 80 x 65	<b>3.500 x 2.875</b> 89 x 73		<b>5.00</b> 127	<b>2.0</b> 0.9
<b>4 x 2</b> 100 x 50	<b>4.500 x 2.375</b> 114 x 60		<b>5.00</b> 127	<b>2.4</b> 1.1
<b>4 x 2-1/2</b> 100 x 65	<b>4.500 x 2.875</b> 114 x 73		<b>5.00</b> 127	<b>2.4</b> 1.1
<b>4 x 3</b> 100 x 80	<b>4.500 x 3.500</b> 114 x 89		<b>5.00</b> 127	<b>2.4</b> 1.1
<b>5 x 3</b> 125 x 80	<b>5.563 x 3.500</b> 141 x 89		<b>9.00</b> 229	<b>4.4</b> 2.0
<b>5 x 4</b> 125 x 100	<b>5.563 x 4.500</b> 141 x 114		<b>9.00</b> 229	<b>4.4</b> 2.0

Schedule 10 dimensions (Schedule 40 dimensions may vary)  
Domestic options available



MAXIMUM WORKING PRESSURE – See specific data sheet for rating of coupling in use.

# Stainless Steel Eccentric Reducer

Model 46E

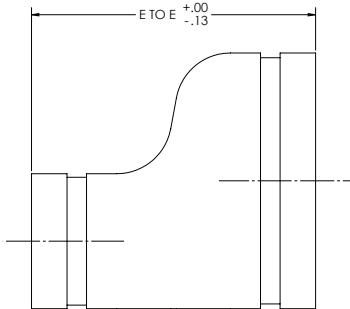

Nominal in mm	Pipe Size		E to E in mm	Weight lbs kg
	O.D. in mm			
<b>6 x 2</b> 150 x 50	<b>6.625 x 2.375</b> 168 x 60		<b>9.00</b> 229	<b>6.6</b> 3.0
<b>6 x 2-1/2</b> 150 x 65	<b>6.625 x 2.875</b> 168 x 73		<b>9.00</b> 229	<b>6.6</b> 3.0
<b>6 x 3</b> 150 x 100	<b>6.625 x 3.500</b> 168 x 89		<b>9.00</b> 229	<b>6.6</b> 3.0
<b>6 x 4</b> 150 x 100	<b>6.625 x 4.500</b> 168 x 114		<b>9.00</b> 128	<b>6.6</b> 3.0
<b>8 x 3</b> 200 x 80	<b>8.625 x 3.500</b> 219 x 89		<b>10.00</b> 254	<b>11.6</b> 5.3
<b>8 x 4</b> 200 x 100	<b>8.625 x 4.500</b> 219 x 114		<b>12.00</b> 305	<b>11.6</b> 5.3
<b>8 x 6</b> 200 x 150	<b>8.625 x 6.625</b> 219 x 168		<b>12.00</b> 203	<b>11.6</b> 5.3
<b>10 x 6</b> 250 x 150	<b>10.750 x 6.625</b> 273 x 168		<b>13.00</b> 330	<b>12.6</b> 5.7
<b>10 x 8</b> 250 x 200	<b>10.750 x 8.625</b> 273 x 219		<b>13.00</b> 330	<b>12.6</b> 5.7
<b>12 x 6</b> 300 x 150	<b>12.750 x 6.625</b> 324 x 168		<b>14.00</b> 356	<b>21.4</b> 9.7
<b>12 x 8</b> 300 x 200	<b>12.750 x 8.625</b> 324 x 219		<b>14.00</b> 356	<b>21.4</b> 9.7
<b>12 x 10</b> 300 x 250	<b>12.750 x 10.750</b> 324 x 273		<b>14.00</b> 356	<b>21.4</b> 9.7

Schedule 10 dimensions (Schedule 40 dimensions may vary)  
Domestic options available



**MAXIMUM WORKING PRESSURE** – See specific data sheet for rating of coupling in use.

# Stainless Steel 11.25° Elbow

Model 461

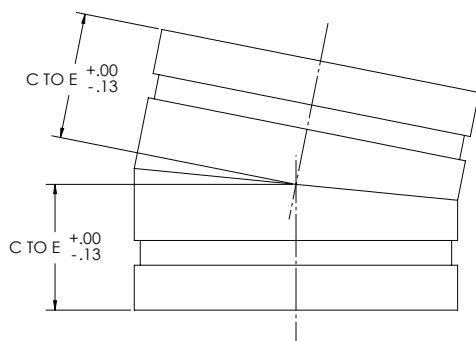
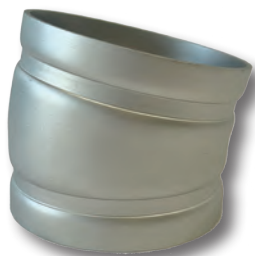

Pipe Size		C to E in mm	Weight lbs kg
Nominal in mm	O.D. in mm		
<b>1-1/2</b>	<b>1.900</b>	<b>1.38</b>	<b>0.6</b>
40	48	35	0.3
<b>2</b>	<b>2.380</b>	<b>1.38</b>	<b>0.8</b>
50	60	35	0.4
<b>2-1/2</b>	<b>2.880</b>	<b>1.50</b>	<b>1.0</b>
65	73	38	0.5
<b>3</b>	<b>3.500</b>	<b>1.50</b>	<b>1.2</b>
80	89	38	0.5
<b>4</b>	<b>4.500</b>	<b>1.75</b>	<b>1.6</b>
100	114	45	0.7
<b>5</b>	<b>5.560</b>	<b>2.00</b>	<b>2.2</b>
125	141	51	1.0
<b>6</b>	<b>6.630</b>	<b>2.00</b>	<b>3.0</b>
150	168	51	1.4
<b>8</b>	<b>8.630</b>	<b>2.00</b>	<b>4.6</b>
200	219	51	2.1
<b>10</b>	<b>10.750</b>	<b>2.13</b>	<b>9.2</b>
250	273	54	4.2
<b>12</b>	<b>12.750</b>	<b>2.25</b>	<b>16.8</b>
300	324	57	7.6
<b>14</b>	<b>14.000</b>	<b>3.50</b>	<b>32.2</b>
350	356	89	14.6
<b>16</b>	<b>16.000</b>	<b>4.00</b>	<b>42.0</b>
400	406	101	19.1
<b>18</b>	<b>18.000</b>	<b>4.50</b>	<b>53.2</b>
450	457	114	24.1
<b>20</b>	<b>20.000</b>	<b>5.00</b>	<b>65.8</b>
500	508	127	29.8
<b>24</b>	<b>24.000</b>	<b>6.00</b>	<b>96.0</b>
600	610	152	43.5

Schedule 10 dimensions (Schedule 40 dimensions may vary)  
Domestic options available

**MAXIMUM WORKING PRESSURE** – See specific data sheet for rating of coupling in use.

# Stainless Steel 22.5° Elbow

Model 462

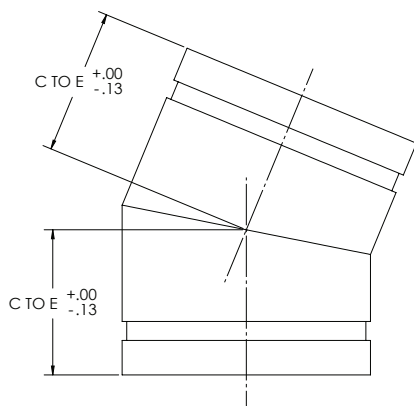

Pipe Size		C to E in mm	Weight lbs kg
Nominal in mm	O.D. in mm		
<b>1-1/2</b>	<b>1.900</b>	<b>1.75</b>	<b>0.8</b>
40	48	45	0.4
<b>2</b>	<b>2.380</b>	<b>1.88</b>	<b>1.2</b>
50	60	48	0.5
<b>2-1/2</b>	<b>2.880</b>	<b>2.00</b>	<b>1.6</b>
65	73	51	0.7
<b>3</b>	<b>3.500</b>	<b>2.25</b>	<b>2.0</b>
80	88	57	0.9
<b>4</b>	<b>4.500</b>	<b>2.63</b>	<b>2.4</b>
100	114	67	1.1
<b>5</b>	<b>5.560</b>	<b>2.88</b>	<b>4.2</b>
125	141	73	1.9
<b>6</b>	<b>6.630</b>	<b>3.13</b>	<b>4.8</b>
150	168	80	2.2
<b>8</b>	<b>8.630</b>	<b>3.88</b>	<b>9.2</b>
200	219	99	4.2
<b>10</b>	<b>10.750</b>	<b>4.38</b>	<b>14.0</b>
250	273	111	6.4
<b>12</b>	<b>12.750</b>	<b>4.88</b>	<b>22.0</b>
300	324	124	10.0
<b>14</b>	<b>14.000</b>	<b>5.00</b>	<b>46.0</b>
350	356	127	20.9
<b>16</b>	<b>16.000</b>	<b>5.00</b>	<b>52.2</b>
400	406	127	23.7
<b>18</b>	<b>18.000</b>	<b>5.50</b>	<b>65.0</b>
450	457	140	29.5
<b>20</b>	<b>20.000</b>	<b>6.00</b>	<b>80.0</b>
500	508	152	36.3
<b>24</b>	<b>24.000</b>	<b>7.00</b>	<b>112.0</b>
600	610	178	50.8

Schedule 10 dimensions (Schedule 40 dimensions may vary)  
Domestic options available

**MAXIMUM WORKING PRESSURE** – See specific data sheet for rating of coupling in use.



# Stainless Steel Cap

Model 46CAP

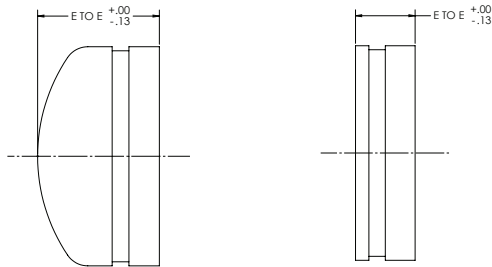
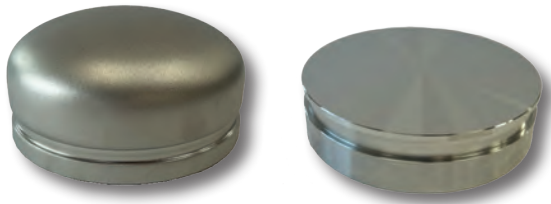

Pipe Size		E to E in mm	Weight lbs kg
Nominal in mm	O.D. in mm		
<b>1</b> 25	<b>1.310</b> 33	<b>1.08</b> 28	<b>0.4</b> 0.2
<b>1-1/4</b> 32	<b>1.660</b> 42	<b>1.08</b> 28	<b>0.5</b> 0.2
<b>1-1/2</b> 40	<b>1.900</b> 48	<b>1.08</b> 28	<b>0.6</b> 0.3
<b>2</b> 50	<b>2.37</b> 60	<b>1.08</b> 28	<b>0.8</b> 0.4
<b>2-1/2</b> 65	<b>2.870</b> 73	<b>1.08</b> 28	<b>1.2</b> 0.5
<b>3</b> 80	<b>3.500</b> 89	<b>1.08</b> 28	<b>1.6</b> 0.7
<b>4</b> 100	<b>4.500</b> 114	<b>1.25</b> 29	<b>2.6</b> 1.2
<b>5</b> 125	<b>5.560</b> 141	<b>3.00</b> 76	<b>2.2</b> 1.0
<b>6</b> 150	<b>6.620</b> 168	<b>3.50</b> 89	<b>3.4</b> 1.5
<b>8</b> 200	<b>8.620</b> 219	<b>4.00</b> 102	<b>5.2</b> 2.4
<b>10</b> 250	<b>10.750</b> 273	<b>5.00</b> 127	<b>9.4</b> 4.3
<b>12</b> 300	<b>12.750</b> 324	<b>6.00</b> 152	<b>15.2</b> 6.9

Schedule 10 dimensions  
(Schedule 40 dimensions may vary)  
Domestic options available

1"-4" machined  
5"-12" roll grooved



MAXIMUM WORKING PRESSURE – See specific data sheet for rating of coupling in use.

# Stainless Steel 45° Lateral

Model 46LAT

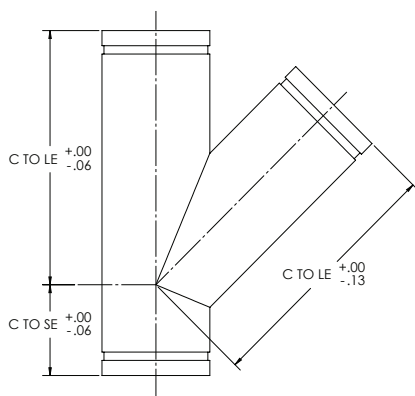

Pipe Size		C to LE in mm	C to SE in mm	Weight lbs kg
Nominal Size in DN/mm	O.D. in mm			
<b>1</b> 25	<b>1.315</b> 34	<b>5.00</b> 127	<b>2.25</b> 57	<b>1.4</b> 0.6
<b>1-1/4</b> 32	<b>1.660</b> 42	<b>5.75</b> 146	<b>2.50</b> 64	<b>1.9</b> 0.9
<b>1-1/2</b> 40	<b>1.900</b> 48	<b>6.25</b> 159	<b>2.75</b> 70	<b>2.6</b> 1.2
<b>2</b> 50	<b>2.375</b> 60	<b>7.00</b> 178	<b>2.75</b> 70	<b>3.2</b> 1.5
<b>2-1/2</b> 65	<b>2.875</b> 73	<b>7.75</b> 197	<b>3.00</b> 76	<b>5.3</b> 2.4
<b>3</b> 80	<b>3.500</b> 89	<b>8.50</b> 216	<b>3.25</b> 83.6	<b>5.8</b> 2.6
<b>4</b> 100	<b>4.500</b> 114	<b>10.50</b> 267	<b>3.75</b> 95	<b>11.2</b> 5.1
<b>6</b> 150	<b>6.625</b> 168	<b>14.00</b> 356	<b>4.50</b> 114	<b>21.0</b> 9.5
<b>8</b> 200	<b>8.625</b> 219	<b>18.00</b> 457	<b>6.00</b> 152	<b>33.2</b> 15.1
<b>10</b> 250	<b>10.750</b> 273	<b>20.50</b> 521	<b>6.50</b> 165	<b>47.6</b> 21.6
<b>12</b> 300	<b>12.750</b> 324	<b>23.00</b> 584	<b>7.00</b> 178	<b>79.2</b> 35.9

Schedule 10 dimensions (Schedule 40 dimensions may vary)  
Domestic options available

# Stainless Steel 45° Reducing Lateral

## Model 46LAT

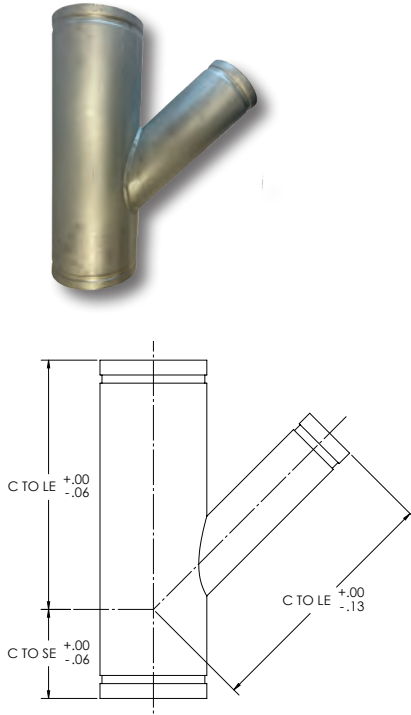

Nominal Pipe Size		C to LE in mm	C to SE in mm	Weight lbs kg
Nominal in mm	O.D. in mm			
<b>3 x 3 x 2</b> 80 x 80 x 50	<b>3.500 x 3.500 x 2.375</b> 89 x 89 x 60	<b>8.50</b> 216	<b>3.25</b> 83	<b>5.6</b> 2.5
<b>3 x 3 x 2-1/2</b> 80 x 80 x 85	<b>3.500 x 3.500 x 2.874</b> 89 x 89 x 73	<b>8.50</b> 216	<b>3.25</b> 83	<b>5.6</b> 2.5
<b>4 x 4 x 2</b> 100 x 100 x 50	<b>4.500 x 4.500 x 2.375</b> 114 x 114 x 60	<b>10.50</b> 267	<b>3.75</b> 95	<b>11.0</b> 5.0
<b>4 x 4 x 2-1/2</b> 100 x 100 x 65	<b>4.500 x 4.500 x 2.874</b> 114 x 114 x 73	<b>10.50</b> 267	<b>3.75</b> 95	<b>11.0</b> 5.0
<b>4 x 4 x 3</b> 100 x 100 x 80	<b>4.500 x 4.500 x 3.500</b> 114 x 114 x 89	<b>10.50</b> 267	<b>3.75</b> 95	<b>11.0</b> 5.0
<b>6 x 6 x 3</b> 150 x 150 x 80	<b>6.625 x 6.625 x 3.500</b> 168 x 168 x 89	<b>14.00</b> 356	<b>4.50</b> 114	<b>20.2</b> 9.2
<b>6 x 6 x 4</b> 150 x 150 x 100	<b>6.625 x 6.625 x 4.500</b> 168 x 168 x 114	<b>14.00</b> 356	<b>4.50</b> 114	<b>20.2</b> 9.2
<b>8 x 8 x 6</b> 200 x 200 x 150	<b>8.625 x 8.625 x 6.625</b> 219 x 219 x 168	<b>18.00</b> 457	<b>6.00</b> 152	<b>33.0</b> 15.0
<b>10 x 10 x 6</b> 250 x 250 x 150	<b>10.750 x 10.750 x 6.625</b> 273 x 273 x 168	<b>20.50</b> 521	<b>6.50</b> 165	<b>47.0</b> 21.3
<b>10 x 10 x 8</b> 250 x 250 x 200	<b>10.750 x 10.750 x 8.625</b> 273 x 273 x 219	<b>20.50</b> 521	<b>6.50</b> 165	<b>47.0</b> 21.3
<b>12 x 12 x 6</b> 300 x 300 x 150	<b>12.750 x 12.750 x 6.625</b> 324 x 324 x 168	<b>23.00</b> 584	<b>7.00</b> 178	<b>76.0</b> 34.5

Schedule 10 dimensions (Schedule 40 dimensions may vary)

Domestic options available

Other reductions available upon request

# Stainless Steel Flange Adaptor

Model 46F

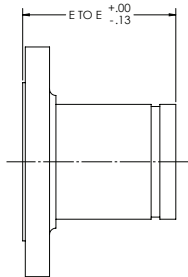
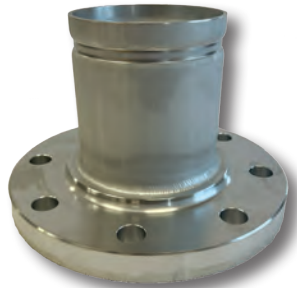

Pipe Size		E to E in mm	Bolt Holes	Weight lbs kg
Nominal in mm	O.D. in mm			
<b>1</b> 25	<b>1.310</b> 33	<b>3.00</b> 76	<b>4</b>	<b>2.4</b> 1.1
<b>1-1/4</b> 32	<b>1.660</b> 42	<b>4.00</b> 102	<b>4</b>	<b>2.8</b> 1.3
<b>1-1/2</b> 40	<b>1.900</b> 48	<b>4.00</b> 102	<b>4</b>	<b>3.6</b> 1.6
<b>2</b> 50	<b>2.370</b> 60	<b>4.00</b> 102	<b>4</b>	<b>5.2</b> 2.4
<b>2-1/2</b> 65	<b>2.870</b> 73	<b>4.00</b> 102	<b>4</b>	<b>9.0</b> 4.1
<b>3</b> 80	<b>3.500</b> 89	<b>4.00</b> 102	<b>4</b>	<b>10.4</b> 4.7
<b>4</b> 100	<b>4.500</b> 114	<b>6.00</b> 152	<b>8</b>	<b>15.0</b> 6.8
<b>5</b> 125	<b>5.560</b> 141	<b>6.00</b> 152	<b>8</b>	<b>19.8</b> 9.0
<b>6</b> 150	<b>6.620</b> 168	<b>6.00</b> 152	<b>8</b>	<b>22.2</b> 10.1
<b>8</b> 200	<b>8.620</b> 219	<b>6.00</b> 152	<b>8</b>	<b>35.4</b> 16.1
<b>10</b> 250	<b>10.750</b> 273	<b>8.00</b> 203	<b>12</b>	<b>51.4</b> 23.3
<b>12</b> 300	<b>12.750</b> 324	<b>8.00</b> 203	<b>12</b>	<b>72.4</b> 32.8

Schedule 10 dimensions  
(Schedule 40 dimensions may vary)  
Domestic options available



# Stainless Steel Cast Flange Adaptor

Model 46FC

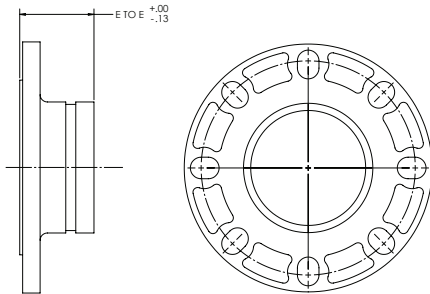

Pipe Size		E to E in mm	Max. Working Pressure psi bar	Bolt Holes	Weight lbs kg
Nominal in mm	O.D. in mm				
2 50	2.370 60	2.37 60	300 21	4	2.8 1.3
2-1/2 65	3.000 76	2.37 60	300 21	8	3.6 1.6
3 80	3.500 89	2.37 60	300 21	8	6.2 2.8
4 100	4.500 114	2.37 60	300 21	8	7.0 3.2
5 125	5.560 141	2.56 65	300 21	8	9.6 4.4
6 150	6.500 165	2.56 65	300 21	8	12.0 5.4
8 200	8.620 219	3.00 76	300 21	8	21.0 9.5

Standard ANSI 150, J1S, 10K, PN16.



**MAXIMUM WORKING PRESSURE** – See specific data sheet for rating of coupling in use.

# Stainless Steel Butterfly Valve

Model BFSVB02

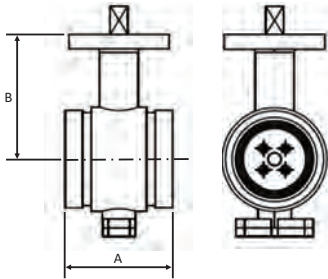

Pipe Size		E to E in mm	Max. Work- ing Pressure psi bar	Weight lbs kg
Nominal in mm	O.D. in mm			
<b>2</b>	<b>2.370</b>	<b>3.19</b>	<b>5.04</b>	<b>7.7</b>
50	60	81	128	3.5
<b>2-1/2</b>	<b>3.000</b>	<b>3.81</b>	<b>4.98</b>	<b>8.4</b>
65	76	97	127	3.8
<b>3</b>	<b>3.500</b>	<b>3.81</b>	<b>4.49</b>	<b>9.9</b>
80	89	97	114	4.5
<b>4</b>	<b>4.500</b>	<b>4.56</b>	<b>4.92</b>	<b>12.8</b>
100	114	116	125	5.8
<b>5</b>	<b>5.560</b>	<b>5.81</b>	<b>5.93</b>	<b>17.6</b>
125	141	148	151	8.0
<b>6</b>	<b>6.500</b>	<b>5.86</b>	<b>6.56</b>	<b>26.5</b>
150	165	149	167	12.0
<b>8</b>	<b>8.620</b>	<b>5.25</b>	<b>8.07</b>	<b>39.7</b>
200	219	133	205	18.0

GroovJoint Model BFSVB02 stainless steel, eccentric grooved-end butterfly valve. Valve is bi-directional, grooved ends are original groove system. Operating temperature depends on the rubber seat being used.

## Maximum Working pressure

2"-8" stainless steel grooved pipe 300 psi (21 bar)

### Body

CF8M

### Disc

CF8M

### Clamp Ring

CF8M

### Shaft

316 SS

### Seat

EPDM (NBR also available)

### O Ring

EPDM (NBR also available)

### Taper Pin

CF8M

### Bottom Cover

CF8M

### Bottom Seal

EPDM (NBR also available)

### Mounting Flange

ISO 5211 Mounting Flange

### Handle

10 Position 304 SS handle and latch plate with SS fasteners. Locking topworks available upon request.

### Seats

EPDM (E)

Temperature range -30°F to +230°F / -34°C to +110°C  
Recommended for Hot/Cold water service It can also be used with a wide variety of dilute acids, oil-free air and many chemical services.

Not recommended for petroleum or steam service.

Nitrile Grade (Buna, NBR)

Temperature range -20°F to +180°F / -29°C to +82°C  
Recommended for petroleum products, air with oil vapors, vegetable oils and mineral oils.

Not recommended for hot water services over +150°F/+66°C or for hot dry air over +140°F/+60°C.

# Fabrication

GroovJoint manufactures a variety of stainless steel custom fabrications and specialty fittings designed to the customer's needs.

Specialty products include, but are not limited to:

- Custom dimension fittings
- Custom reduction tees and reducers
- Grooved laterals & wyes
- Large diameter grooved reducing tees
- 3D grooved elbows
- Grooved spool pieces
- Groove by press fittings
- Groove by male or female thread fittings



# Schedule 40 Stainless Steel Fittings

As part of our product offering, GroovJoint stocks schedule 40 stainless steel fittings in both 304L and 316L grades.

Sizes range from 1"-12" and 14"-24" fittings may be available upon request.

All Sch. 40 fittings are designed to be as close to the Sch. 10 dimensions where possible. All dimensions are available on request.

Domestic options available

Most products can be offered in either a roll grooved end or a cut grooved end (depending on the customers needs).

Fittings include, but are not limited to:

- Grooved and Thread Nipples
- Flange Adaptors
- Laterals
- True Wye's
- Crosses
- Transition Fittings
- 22-1/2° Elbows
- 11-1/4° Elbows





**GROOVJOINT STANDARD ROLL GROOVE SPECIFICATION  
FOR STEEL & OTHER IPS OR ISO SIZE PIPE**

-1-	-2-			-3-	-4-	-5-		-6-	-7-	-8-
Nominal Pipe Size	O.D.			A ±0.030/ ±0.76	B ±0.030/ ±0.76	C Actual	C Tol. +0.000	D (Ref. Only)	T Min. Allow. Wall Thick	Max. Flare Dia.
	Actual	Tolerance								
In./DN(mm)	In./mm	+In./mm	-In./mm	In./mm	In./mm	In./mm	-In./mm	In./mm	In./mm	In./mm
<b>1</b> 25	<b>1.315</b> 33.4	<b>+0.028</b> +0.71	<b>-0.015</b> -0.38	<b>0.625</b> 15.88	<b>0.281</b> 7.14	<b>1.190</b> 30.23	<b>-0.015</b> -0.38	<b>0.063</b> 1.60	<b>0.065</b> 1.7	<b>1.430</b> 36.3
<b>1-1/4</b> 32	<b>1.660</b> 42.2	<b>+0.029</b> +0.74	<b>-0.016</b> -0.41	<b>0.625</b> 15.88	<b>0.281</b> 7.14	<b>1.535</b> 38.99	<b>-0.015</b> -0.38	<b>0.063</b> 1.60	<b>0.065</b> 1.7	<b>1.770</b> 45.0
<b>1-1/2</b> 40	<b>1.900</b> 48.3	<b>+0.019</b> +0.48	<b>-0.019</b> -0.48	<b>0.625</b> 15.88	<b>0.281</b> 7.14	<b>1.775</b> 45.09	<b>-0.015</b> -0.38	<b>0.063</b> 1.60	<b>0.065</b> 1.7	<b>2.010</b> 51.1
<b>2</b> 50	<b>2.375</b> 60.3	<b>+0.024</b> +0.61	<b>-0.024</b> -0.61	<b>0.625</b> 15.88	<b>0.344</b> 8.74	<b>2.250</b> 57.15	<b>-0.015</b> -0.38	<b>0.063</b> 1.60	<b>0.065</b> 1.7	<b>2.480</b> 63.0
<b>2-1/2</b> 65	<b>2.875</b> 73.0	<b>+0.029</b> +0.74	<b>-0.029</b> -0.74	<b>0.625</b> 15.88	<b>0.344</b> 8.74	<b>2.720</b> 69.09	<b>-0.018</b> -0.46	<b>0.078</b> 1.98	<b>0.083</b> 2.1	<b>2.980</b> 75.7
<b>3</b> 80	<b>3.500</b> 88.9	<b>+0.035</b> +0.89	<b>-0.031</b> -0.79	<b>0.625</b> 15.88	<b>0.344</b> 8.74	<b>3.344</b> 84.94	<b>-0.018</b> -0.46	<b>0.078</b> 1.98	<b>0.083</b> 2.1	<b>3.600</b> 91.4
<b>3-1/2</b> 90	<b>4.000</b> 101.6	<b>+0.040</b> +1.02	<b>-0.031</b> -0.79	<b>0.625</b> 15.88	<b>0.344</b> 8.74	<b>3.834</b> 97.38	<b>-0.020</b> -0.51	<b>0.083</b> 2.11	<b>0.083</b> 2.1	<b>4.100</b> 104.1
<b>4</b> 100	<b>4.500</b> 114.3	<b>+0.045</b> +1.14	<b>-0.031</b> -0.79	<b>0.625</b> 15.88	<b>0.344</b> 8.74	<b>4.334</b> 110.08	<b>-0.020</b> -0.51	<b>0.083</b> 2.11	<b>0.083</b> 2.1	<b>4.600</b> 116.8
<b>5</b> 125	<b>5.563</b> 141.3	<b>+0.056</b> +1.42	<b>-0.031</b> -0.79	<b>0.625</b> 15.88	<b>0.344</b> 8.74	<b>5.395</b> 137.03	<b>-0.022</b> -0.56	<b>0.084</b> 2.13	<b>0.109</b> 2.8	<b>5.660</b> 143.8
<b>6</b> 150	<b>6.625</b> 168.3	<b>+0.063</b> +1.60	<b>-0.031</b> -0.79	<b>0.625</b> 15.88	<b>0.344</b> 8.74	<b>6.455</b> 163.96	<b>-0.022</b> -0.56	<b>0.085</b> 2.16	<b>0.109</b> 2.8	<b>6.730</b> 170.9
<b>8</b> 200	<b>8.625</b> 219.1	<b>+0.063</b> +1.60	<b>-0.031</b> -0.79	<b>0.750</b> 19.05	<b>0.469</b> 11.91	<b>8.441</b> 214.40	<b>-0.025</b> -0.64	<b>0.092</b> 2.34	<b>0.109</b> 2.8	<b>8.800</b> 223.5
<b>10</b> 250	<b>10.750</b> 273.1	<b>+0.063</b> +1.60	<b>-0.031</b> -0.79	<b>0.750</b> 19.05	<b>0.469</b> 11.91	<b>10.562</b> 268.27	<b>-0.027</b> -0.69	<b>0.094</b> 2.39	<b>0.134</b> 3.4	<b>10.920</b> 277.4
<b>12</b> 300	<b>12.750</b> 323.9	<b>+0.063</b> +1.60	<b>-0.031</b> -0.79	<b>0.750</b> 19.05	<b>0.469</b> 11.91	<b>12.531</b> 318.29	<b>-0.030</b> -0.76	<b>0.109</b> 2.77	<b>0.156</b> 4.0	<b>12.920</b> 328.2
<b>14 O.D.</b> 355.6	<b>14.000</b> 355.6	<b>+0.063</b> +1.60	<b>-0.031</b> -0.79	<b>0.938</b> 23.83	<b>0.469</b> 11.91	<b>13.781</b> 350.04	<b>-0.030</b> -0.76	<b>0.109</b> 2.77	<b>0.156</b> 4.0	<b>14.100</b> 358.1
<b>16 O.D.</b> 406.4	<b>16.000</b> 406.4	<b>+0.063</b> +1.60	<b>-0.031</b> -0.79	<b>0.938</b> 23.83	<b>0.469</b> 11.91	<b>15.781</b> 400.84	<b>-0.030</b> -0.76	<b>0.109</b> 2.77	<b>0.165</b> 4.2	<b>16.100</b> 408.9
<b>18 O.D.</b> 457.2	<b>18.000</b> 457.2	<b>+0.063</b> +1.60	<b>-0.031</b> -0.79	<b>1.000</b> 25.40	<b>0.469</b> 11.91	<b>17.781</b> 451.64	<b>-0.030</b> -0.76	<b>0.109</b> 2.77	<b>0.165</b> 4.2	<b>18.160</b> 461.3
<b>20 O.D.</b> 508.0	<b>20.000</b> 508.0	<b>+0.063</b> +1.60	<b>-0.031</b> -0.79	<b>1.000</b> 25.40	<b>0.469</b> 11.91	<b>19.781</b> 502.44	<b>-0.030</b> -0.76	<b>0.109</b> 2.77	<b>0.188</b> 4.8	<b>20.160</b> 512.1
<b>24 O.D.</b> 609.6	<b>24.000</b> 609.6	<b>+0.063</b> +1.60	<b>-0.031</b> -0.79	<b>1.000</b> 25.40	<b>0.563</b> 14.30	<b>23.656</b> 600.86	<b>-0.030</b> -0.76	<b>0.172</b> 4.37	<b>0.218</b> 5.5	<b>24.200</b> 614.7
<b>30 O.D.</b> 762.0	<b>30.000</b> 762.0	<b>+0.093</b> 2.36	<b>-0.031</b> 0.79	<b>1.750▼</b> 44.45	<b>0.625</b> 15.88	<b>29.500</b> 749.30	<b>-0.063</b> 1.60	<b>0.250</b> 6.35	<b>0.250</b> 6.35	<b>30.200</b> 761.1

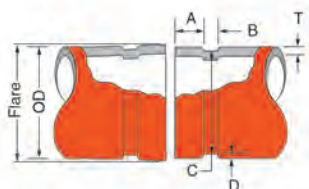

**GROOVJOINT STANDARD CUT GROOVE SPECIFICATION  
FOR STEEL & OTHER IPS OR ISO SIZE PIPE**

-1-	-2-			-3-	-4-	-5-		-6-	-7-
Nominal Pipe Size	O.D.			A ±0.030/ ±0.76	B ±0.030/ ±0.76	C Actual	C Tol. +0.000	D (Ref. Only)	T Min. Allow. Wall Thick
	Actual	Tolerance							
In./DN(mm)	In./mm	+In./mm	-In./mm	In./mm	In./mm	In./mm	In./mm	In./mm	In./mm
<b>1</b> 25	<b>1.315</b> 33.4	<b>+0.028</b> +0.71	<b>-0.015</b> -0.38	<b>0.625</b> 15.88	<b>0.312</b> 7.92	<b>1.190</b> 30.23	<b>-0.015</b> -0.38	<b>0.062</b> 1.6	<b>0.133</b> 3.4
<b>1-1/4</b> 32	<b>1.660</b> 42.2	<b>+0.029</b> +0.74	<b>-0.016</b> -0.41	<b>0.625</b> 15.88	<b>0.312</b> 7.92	<b>1.535</b> 38.99	<b>-0.015</b> -0.38	<b>0.062</b> 1.6	<b>0.140</b> 3.6
<b>1-1/2</b> 40	<b>1.900</b> 48.3	<b>+0.019</b> +0.48	<b>-0.019</b> -0.48	<b>0.625</b> 15.88	<b>0.312</b> 7.92	<b>1.775</b> 45.09	<b>-0.015</b> -0.38	<b>0.062</b> 1.6	<b>0.145</b> 3.7
<b>2</b> 50	<b>2.375</b> 60.3	<b>+0.024</b> +0.61	<b>-0.024</b> -0.61	<b>0.625</b> 15.88	<b>0.312</b> 7.92	<b>2.250</b> 57.15	<b>-0.015</b> -0.38	<b>0.062</b> 1.6	<b>0.154</b> 3.9
<b>2-1/2</b> 65	<b>2.875</b> 73.0	<b>+0.029</b> +0.74	<b>-0.029</b> -0.74	<b>0.625</b> 15.88	<b>0.312</b> 7.92	<b>2.720</b> 69.09	<b>-0.018</b> -0.46	<b>0.078</b> 2.0	<b>0.187</b> 4.8
<b>3</b> 80	<b>3.500</b> 88.9	<b>+0.035</b> +0.89	<b>-0.031</b> -0.79	<b>0.625</b> 15.88	<b>0.312</b> 7.92	<b>3.344</b> 84.94	<b>-0.018</b> -0.46	<b>0.078</b> 2.0	<b>0.188</b> 4.8
<b>3-1/2</b> 90	<b>4.000</b> 101.6	<b>+0.040</b> +1.02	<b>-0.031</b> -0.79	<b>0.625</b> 15.88	<b>0.312</b> 7.92	<b>3.834</b> 97.38	<b>-0.020</b> -0.51	<b>0.083</b> 2.1	<b>0.188</b> 4.8
<b>4</b> 100	<b>4.500</b> 114.3	<b>+0.045</b> +1.14	<b>-0.031</b> -0.79	<b>0.625</b> 15.88	<b>0.375</b> 9.53	<b>4.334</b> 110.08	<b>-0.020</b> -0.51	<b>0.083</b> 2.1	<b>0.203</b> 5.2
<b>5</b> 125	<b>5.563</b> 141.3	<b>+0.056</b> +1.42	<b>-0.031</b> -0.79	<b>0.625</b> 15.88	<b>0.375</b> 9.53	<b>5.395</b> 137.03	<b>-0.022</b> -0.56	<b>0.084</b> 2.1	<b>0.203</b> 5.2
<b>6</b> 150	<b>6.625</b> 168.3	<b>+0.063</b> +1.60	<b>-0.031</b> -0.79	<b>0.625</b> 15.88	<b>0.375</b> 9.53	<b>6.455</b> 163.96	<b>-0.022</b> -0.56	<b>0.085</b> 2.2	<b>0.219</b> 5.6
<b>8</b> 200	<b>8.625</b> 219.1	<b>+0.063</b> +1.60	<b>-0.031</b> -0.79	<b>0.750</b> 19.05	<b>0.437</b> 11.10	<b>8.441</b> 214.40	<b>-0.025</b> -0.64	<b>0.092</b> 2.3	<b>0.238</b> 6.1
<b>10</b> 250	<b>10.750</b> 273.1	<b>+0.063</b> +1.60	<b>-0.031</b> -0.79	<b>0.750</b> 19.05	<b>0.500</b> 12.70	<b>10.562</b> 268.27	<b>-0.027</b> -0.69	<b>0.094</b> 2.4	<b>0.250</b> 6.4
<b>12</b> 300	<b>12.750</b> 323.9	<b>+0.063</b> +1.60	<b>-0.031</b> -0.79	<b>0.750</b> 19.05	<b>0.500</b> 12.70	<b>12.531</b> 318.29	<b>-0.030</b> -0.76	<b>0.109</b> 2.8	<b>0.279</b> 7.1
<b>14 O.D.</b> 355.6	<b>14.000</b> 355.6	<b>+0.063</b> +1.60	<b>-0.031</b> -0.79	<b>0.938</b> 23.83	<b>0.500</b> 12.70	<b>13.781</b> 350.04	<b>-0.030</b> -0.76	<b>0.109</b> 2.8	<b>0.281</b> 7.1
<b>16 O.D.</b> 406.4	<b>16.000</b> 406.4	<b>+0.063</b> +1.60	<b>-0.031</b> -0.79	<b>0.938</b> 23.83	<b>0.500</b> 12.70	<b>15.781</b> 400.84	<b>-0.030</b> -0.76	<b>0.109</b> 2.8	<b>0.312</b> 7.9
<b>18 O.D.</b> 457.2	<b>18.000</b> 457.2	<b>+0.063</b> +1.60	<b>-0.031</b> -0.79	<b>1.000</b> 25.40	<b>0.500</b> 12.70	<b>17.781</b> 451.64	<b>-0.030</b> -0.76	<b>0.109</b> 2.8	<b>0.312</b> 7.9
<b>20 O.D.</b> 508.0	<b>20.000</b> 508.0	<b>+0.063</b> +1.60	<b>-0.031</b> -0.79	<b>1.000</b> 25.40	<b>0.500</b> 12.70	<b>19.781</b> 502.44	<b>-0.030</b> -0.76	<b>0.109</b> 2.8	<b>0.312</b> 7.9
<b>24 O.D.</b> 609.6	<b>24.000</b> 609.6	<b>+0.063</b> +1.60	<b>-0.031</b> -0.79	<b>1.000</b> 25.40	<b>0.563</b> 14.30	<b>23.656</b> 600.86	<b>-0.030</b> -0.76	<b>0.172</b> 4.4	<b>0.375</b> 9.5
<b>28 I.D.</b> 733.4	<b>28.875</b> 733.4	<b>+0.063</b> +1.60	<b>-0.031</b> -0.79	<b>1.000</b> 25.40	<b>0.563</b> 14.30	<b>28.531</b> 724.69	<b>-0.030</b> -0.76	<b>0.172</b> 4.4	<b>0.437</b> 11.1
<b>30 I.D.</b> 787.4	<b>31.000</b> 787.4	<b>+0.063</b> +1.60	<b>-0.031</b> -0.79	<b>1.250</b> 31.75	<b>.0625</b> 15.88	<b>30.594</b> 777.09	<b>-.030</b> -0.76	<b>0.203</b> 5.2	<b>0.500</b> 12.7
<b>30 O.D.</b> 762.0	<b>30.000</b> 762.0	<b>0.093</b> 2.36	<b>0.031</b> 0.79	<b>1.750▼</b> 44.45	<b>0.625</b> 15.88	<b>29.500</b> 749.30	<b>0.063</b> 1.60	<b>0.250</b> 6.35	<b>0.625</b> 15.88

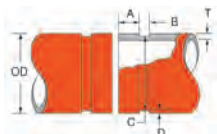

# PressJoint Stainless Steel Press Style Fittings

This section displays our complete line of PressJoint products. The innovative stainless steel pipe and pressfit system allows pipe systems to be efficiently installed without welding, while saving the customer valuable time and money.

Primary applications include, but are not limited to: compressed air, heating facilities, sanitation facilities, fire-extinguishing sprinkler systems, solar energy, plumbing, industrial buildings, shipping centers, and mining.



Certified to NSF/ANSI 61



Certified to NSF/ANSI 61-G



# Press Fitting Recommendations

PressJoint stainless steel fittings are press-style stainless steel fittings offered in sizes ranging from 1/2" to 2" and can be installed on both Schedule 5 and Schedule 10 stainless steel pipe. Our products have a maximum pressure rating of 300 psi (temperature dependent) when installed using an approved press tool.

## TECHNICAL DATA

**Approvals:** PressJoint stainless steel fittings are NSF/ANSI 61 Certified and FM approved.

**Working Temperature:** Depending on O-Ring seal selection, temperatures range from -22°F to 300°F. Refer to the O-Ring seals below for specific temperature ranges.

**Threaded Connections:** All threaded connections meet ANSI/ASME B 1.20.1 NPT.

**Flange Connections:** Flange connections are compatible with ANSI Class 125/150 bolt patterns.

## MATERIAL SPECIFICATIONS

**Fitting Housing:** Stainless Steel per ANSI 316/316L with a wall thickness of 0.059" (1.5mm) and the following characteristics:

- Hygienic, as demonstrated in the food, beverage, and pharmaceutical industries
- Less heat conduction than other materials
- The use of molybdenum results in excellent performance in chlorinated environments

**Working Pressure:** The working pressure range is from full vacuum to 300 psi (21 bar) on Sch. 5 and Sch. 10 stainless steel pipe.

**O-Rings:** O-Ring style gaskets are resistant to hot water, aging, and additives commonly used in drinking water.

- **EPDM Grade "E" (green stripe)**

-4°F to 230°F (-20°C to 110°C). For cold and hot water, heating systems, oil-free compressed air systems and many chemical services. Excellent oxidation resistance. NOT FOR USE WITH HYDROCARBONS.



- **Nitrile Grade (Buna, NBR) "T" (orange stripe)**

-13°F to 230°F (-25°C to 110°C). Petroleum products (except diesel), vegetable oils, mineral oils, and compressed air with oils. NOT FOR USE WITH HOT WATER OR HOT DRY AIR.



- **Fluorelastomer Grade (Viton, FKM) "O" (blue stripe)**

-4°F to 356°F (-20°C to 180°C). Hydraulic fluids, process water, chlorinated hydrocarbons and oxidizing acids. NOT FOR USE WITH AMMONIA.



## Product Code Detail

**PJ**

Prefix

**E**

Gasket

**90**

Item Code

**100**

Pipe Diameter

# Stainless Steel Press Coupling

PJECOUP

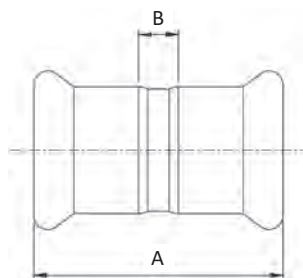

Pipe Size		Dimensions		Weight lbs kg
Nominal in mm	O.D. in mm	A in mm	B in mm	
1/2 15	0.840 21	2.1 53	0.4 11	0.13 0.1
3/4 20	1.050 27	2.3 59	0.4 11	0.18 0.1
1 25	1.315 33	2.5 63	0.4 11	0.23 0.1
1-1/2 40	1.900 48	2.8 72	0.4 11	0.40 0.2
2 50	2.375 60	4.1 103	0.5 13	0.74 0.3

# Stainless Steel Press Slip Coupling

PJESCOUP

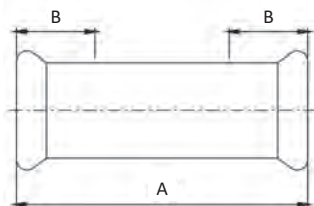

Pipe Size		Dimensions		Weight lbs kg
Nominal in mm	O.D. in mm	A in mm	B in mm	
1/2 15	0.840 21	3.0 75	0.8 21	0.18 0.1
3/4 20	1.050 27	3.4 86	1.0 24	0.25 0.1
1 25	1.315 33	3.8 97	1.0 26	0.34 0.2
1-1/2 40	1.900 48	4.8 122	1.2 30	0.63 0.3
2 50	2.375 60	6.8 172	1.8 45	1.13 0.5



# Stainless Steel Press 90° Elbow

PJE90

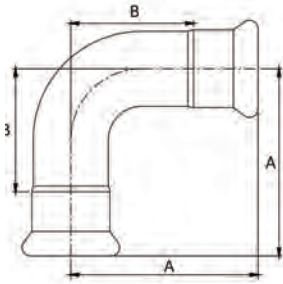

Pipe Size		Dimensions		Weight lbs kg
Nominal in mm	O.D. in mm	A in mm	B in mm	
1/2 15	0.840 21	2.4 61	1.6 40	0.22 0.1
3/4 20	1.050 27	2.8 72	1.9 48	0.33 0.2
1 25	1.315 33	3.4 86	2.4 60	0.48 0.2
1-1/2 40	1.900 48	3.8 96	2.6 65	0.79 0.4
2 50	2.375 60	5.0 127	3.2 82	1.39 0.6

# Stainless Steel Press 90° Street Elbow

PJE90M

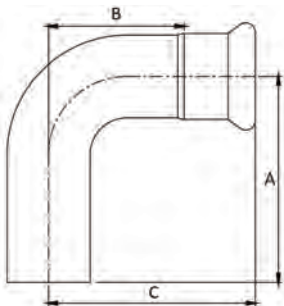

Pipe Size		Dimensions			Weight lbs kg
Nominal IN mm	O.D. in mm	A in mm	B in mm	C in mm	
1/2 15	0.840 21	2.9 73	1.6 40	2.4 61	0.24 0.1
3/4 20	1.050 27	3.3 83	1.9 48	2.8 72	0.33 0.2
1 25	1.315 33	3.9 99	2.4 60	3.4 86	0.37 0.2
1-1/2 40	1.900 48	4.1 103	2.5 63	3.7 94	0.77 0.4
2 50	2.375 60	5.5 140	3.2 82	5.0 127	1.34 0.6



Certified to  
NSF/ANSI 61-G



# Stainless Steel Press 45° Elbow

PJE45

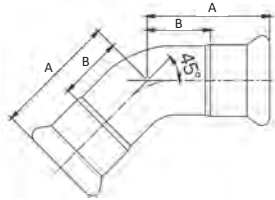

Pipe Size		Dimensions		Weight lbs kg
Nominal in mm	O.D. in mm	A in mm	B in mm	
1/2 15	0.840 21	1.6 41	0.8 20	0.18 0.1
3/4 20	1.050 27	1.9 47	0.9 23	0.24 0.2
1 25	1.315 33	2.1 54	1.1 29	0.37 0.2
1-1/2 40	1.900 48	2.4 60	1.2 30	0.59 0.3
2 50	2.375 60	3.2 82	1.5 38	1.06 0.5

# Stainless Steel Press 45° Street Elbow

PJE45M

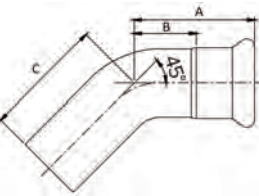

Pipe Size		Dimensions			Weight lbs kg
Nominal in mm	O.D. in mm	A in mm	B in mm	C in mm	
1/2 15	0.840 21	1.6 41	0.8 20	2.1 53	0.20 0.1
3/4 20	1.050 27	1.9 47	0.9 23	2.3 58	0.26 0.2
1 25	1.315 33	2.1 54	1.1 29	2.7 67	0.37 0.2
1-1/2 40	1.900 48	2.4 60	1.2 30	2.7 70	0.60 0.3
2 50	2.375 60	3.2 82	1.5 38	3.8 95	1.06 0.5



Certified to  
NSF/ANSI 61-G



# Stainless Steel Press Tee

PJET

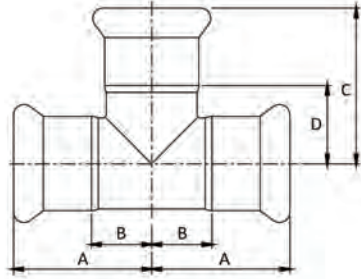

Pipe Size		Dimensions				Weight lbs kg
Nominal in mm	O.D. in mm	A in mm	B in mm	C in mm	D in mm	
1/2 15	0.840 21	1.5 38	0.6 16	1.6 42	0.8 20	0.24 0.1
3/4 20	1.050 27	1.7 43	0.8 19	1.9 47	0.9 23	0.33 0.2
1 25	1.315 33	1.9 49	0.9 23	2.1 54	1.1 28	0.46 0.2
1-1/2 40	1.900 48	2.8 71	1.6 41	2.6 67	1.4 36	0.92 0.4
2 50	2.375 60	3.4 86	1.6 41	3.4 86	1.6 41	1.48 0.7





# Stainless Steel Press Reducing Tee

PJET

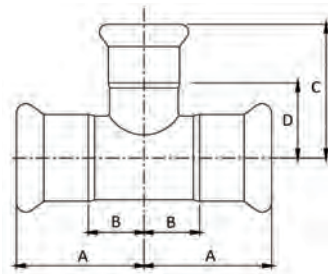

Pipe Size		Dimensions				Weight lbs kg
Nominal in mm	O.D. in mm	A in mm	B in mm	C in mm	D in mm	
<b>3/4 x 1/2 x 3/4</b> 20 x 15 20	<b>1.05 x 0.84 x 1.05</b> 27 x 21 x 27	<b>1.7</b> 43	<b>0.8</b> 19	<b>1.7</b> 44	<b>0.9</b> 23	<b>0.31</b> 0.1
<b>1 x 1/2 x 1</b> 25 x 15 x 25	<b>1.32 x 0.84 x 1.32</b> 33 x 21 x 33	<b>1.9</b> 49	<b>0.9</b> 23	<b>1.9</b> 48	<b>1.1</b> 27	<b>0.40</b> 0.2
<b>1 x 3/4 x 1</b> 25 x 20 x 25	<b>1.32 x 1.05 x 1.32</b> 33 x 27 x 33	<b>1.9</b> 49	<b>0.9</b> 23	<b>2.0</b> 51	<b>1.1</b> 27	<b>0.42</b> 0.2
<b>1-1/2 x 1/2 x 1-1/2</b> 40 x 15 x 40	<b>1.90 x 0.84 x 1.90</b> 48 x 21 x 48	<b>2.8</b> 71	<b>1.6</b> 40	<b>2.2</b> 56	<b>1.4</b> 34	<b>0.79</b> 0.4
<b>1-1/2 x 3/4 x 1-1/2</b> 40 x 20 x 40	<b>1.90 x 1.05 x 1.90</b> 48 x 27 x 48	<b>2.8</b> 71	<b>1.6</b> 40	<b>2.3</b> 59	<b>1.4</b> 35	<b>0.81</b> 0.4
<b>1-1/2 x 1 x 1-1/2</b> 40 x 25 x 40	<b>1.90 x 1.32 x 1.90</b> 48 x 33 x 48	<b>2.8</b> 71	<b>1.6</b> 40	<b>2.5</b> 62	<b>1.4</b> 36	<b>0.84</b> 0.4
<b>2 x 1/2 x 2</b> 50 x 15 x 50	<b>2.38 x 0.84 x 2.38</b> 60 x 21 x 60	<b>3.4</b> 86	<b>1.6</b> 41	<b>2.4</b> 62	<b>1.6</b> 41	<b>1.17</b> 0.5
<b>2 x 3/4 x 2</b> 50 x 20 x 50	<b>2.38 x 1.05 x 2.38</b> 60 x 27 x 60	<b>3.4</b> 86	<b>1.6</b> 41	<b>2.6</b> 65	<b>1.6</b> 41	<b>1.19</b> 0.5
<b>2 x 1 x 2</b> 50 x 25 x 50	<b>2.38 x 1.32 x 2.38</b> 60 x 33 x 60	<b>3.4</b> 86	<b>1.6</b> 41	<b>2.6</b> 67	<b>1.6</b> 41	<b>1.23</b> 0.6
<b>2 x 1-1/2 x 2</b> 50 x 40 x 50	<b>2.38 x 1.90 x 2.38</b> 60 x 48 x 60	<b>3.4</b> 86	<b>1.6</b> 41	<b>2.8</b> 72	<b>1.6</b> 41	<b>1.32</b> 0.6



Certified to  
NSF/ANSI 61-G



# Stainless Steel Press Reducing Tee FPT Branch

PJEFT

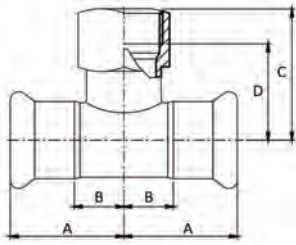

Pipe Size		Dimensions				Weight lbs kg
Nominal in mm	O.D. in mm	A in mm	B in mm	C in mm	D in mm	
1/2 x 1/2 x 1/2 15 x 15 x 15	0.84 x 0.84 x 0.84 21 x 21 x 21	1.5 38	0.6 16	1.5 39	0.9 24	0.26 0.1
1/2 x 3/4 x 1/2 15 x 20 x 15	0.84 x 1.05 x 0.84 21 x 27 x 21	1.5 38	0.6 16	1.8 47	1.3 33	0.37 0.2
3/4 x 1/2 x 3/4 20 x 15 x 20	1.05 x 0.84 x 1.05 27 x 21 x 27	1.7 43	0.8 19	1.6 41	1.0 26	0.33 0.2
3/4 x 3/4 x 3/4 20 x 20 x 20	1.05 x 1.05 x 1.05 27 x 27 x 27	1.7 43	0.8 19	1.8 46	1.3 32	0.40 0.2
3/4 x 1 x 3/4 20 x 25 x 20	1.05 x 1.32 x 1.05 27 x 33 x 27	1.7 43	0.8 19	2.0 50	1.3 33	0.46 0.2
1 x 1/2 x 1 25 x 15 x 25	1.32 x 0.84 x 1.32 33 x 21 x 33	1.9 49	0.9 23	1.8 45	1.1 28	0.42 0.2
1 x 3/4 x 1 25 x 20 x 25	1.32 x 1.05 x 1.32 33 x 27 x 33	1.9 49	0.9 23	1.9 49	1.3 32	0.48 0.2
1 x 1 x 1 25 x 25 x 25	1.32 x 1.32 x 1.32 33 x 33 x 33	1.9 49	0.9 23	2.0 51	1.2 31	0.65 0.3
1-1/2 x 1/2 x 1-1/2 40 x 15 x 40	1.90 x 0.84 x 1.90 48 x 21 x 48	2.8 71	1.6 40	2.1 53	1.5 38	0.85 0.4
1-1/2 x 3/4 x 1-1/2 40 x 20 x 40	1.90 x 1.05 x 1.90 48 x 27 x 48	2.8 71	1.6 40	2.3 57	1.7 43	0.91 0.4
1-1/2 x 1 x 1-1/2 40 x 25 x 40	1.90 x 1.32 x 1.90 48 x 33 x 48	2.8 71	1.6 40	2.3 58	1.6 40	1.03 0.5
1-1/2 x 1-1/2 x 1-1/2 40 x 40 x 40	1.90 x 1.90 x 1.90 48 x 48 x 48	2.8 71	1.6 40	2.6 66	1.7 44	1.27 0.6
2 x 1/2 x 2 50 x 15 x 50	2.38 x 0.84 x 2.38 60 x 21 x 60	3.4 86	1.6 41	2.3 59	1.7 44	1.19 0.5
2 x 3/4 x 2 50 x 20 x 50	2.38 x 1.05 x 2.38 60 x 27 x 60	3.4 86	1.6 41	2.5 64	2.0 50	1.26 0.6
2 x 1 x 2 50 x 25 x 50	2.38 x 1.32 x 2.38 60 x 33 x 60	3.4 86	1.6 41	2.5 64	1.8 47	1.32 0.6
2 x 2 x 2 50 x 50 x 50	2.38 x 2.38 x 2.38 60 x 60 x 60	3.4 86	1.6 41	3.2 81	2.1 54	1.90 0.9



Certified to  
NSF/ANSI 61-G



# Stainless Steel Press Reducer

PJEFP

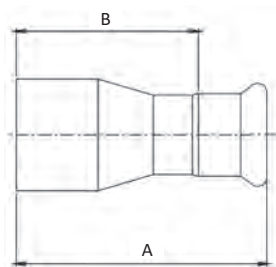

Pipe Size		Dimensions		Weight lbs kg
Nominal in mm	O.D. in mm	A in mm	B in mm	
<b>3/4 x 1/2</b> 20 x 15	<b>1.05 x 0.84</b> 27 x 21	<b>3.0</b> 77	<b>2.2</b> 56	<b>0.18</b> 0.1
<b>1 x 1/2</b> 25 x 15	<b>1.32 x 0.84</b> 33 x 21	<b>3.3</b> 83	<b>2.4</b> 62	<b>0.23</b> 0.1
<b>1 x 3/4</b> 25 x 20	<b>1.32 x 1.05</b> 33 x 27	<b>3.8</b> 96	<b>2.8</b> 71	<b>0.26</b> 0.1
<b>1-1/2 x 1/2</b> 40 x 15	<b>1.90 x 0.84</b> 48 x 21	<b>3.5</b> 88	<b>2.6</b> 67	<b>0.33</b> 0.1
<b>1-1/2 x 3/4</b> 40 x 20	<b>1.90 x 1.05</b> 48 x 27	<b>3.6</b> 90	<b>2.6</b> 66	<b>0.55</b> 0.2
<b>1-1/2 x 1</b> 40 x 25	<b>1.90 x 1.32</b> 48 x 33	<b>4.3</b> 108	<b>3.2</b> 82	<b>0.39</b> 0.2
<b>2 x 1/2</b> 50 x 15	<b>2.38 x 0.84</b> 60 x 21	<b>4.2</b> 106	<b>3.3</b> 85	<b>0.53</b> 0.2
<b>2 x 3/4</b> 50 x 20	<b>2.38 x 1.05</b> 60 x 27	<b>4.3</b> 108	<b>3.3</b> 84	<b>0.35</b> 0.2
<b>2 x 1</b> 50 x 25	<b>2.38 x 1.05</b> 60 x 33	<b>4.3</b> 110	<b>3.3</b> 84	<b>0.57</b> 0.3
<b>2 x 1-1/2</b> 50 x 40	<b>2.38 x 1.90</b> 60 x 48	<b>4.8</b> 121	<b>3.6</b> 91	<b>0.72</b> 0.3



Certified to  
NSF/ANSI 61-G



# Stainless Steel Press Ball Valve

PJEVLV

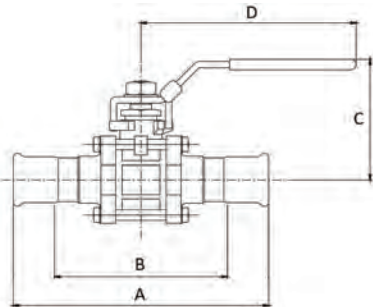

Pipe Size		Dimensions				Weight lbs mm
Nominal in mm	O.D. in mm	A in mm	B in mm	C in mm	D in mm	
<b>1/2</b> 15	<b>0.840</b> 21	<b>5.0</b> 127	<b>3.3</b> 85	<b>2.2</b> 55	<b>3.7</b> 95	<b>1.24</b> 0.6
<b>3/4</b> 20	<b>1.050</b> 27	<b>5.5</b> 139	<b>3.6</b> 91	<b>2.5</b> 63	<b>4.3</b> 110	<b>1.73</b> 0.8
<b>1</b> 25	<b>1.315</b> 33	<b>6.1</b> 154	<b>4.0</b> 102	<b>2.9</b> 74	<b>5.3</b> 135	<b>2.46</b> 1.1
<b>1-1/2</b> 40	<b>1.900</b> 48	<b>7.1</b> 181	<b>5.0</b> 126	<b>3.6</b> 92	<b>6.6</b> 168	<b>5.93</b> 2.7
<b>2</b> 50	<b>2.375</b> 60	<b>9.4</b> 238	<b>5.8</b> 148	<b>4.2</b> 107	<b>7.1</b> 180	<b>8.48</b> 3.8



# Stainless Steel Press Female Adaptor

PJEFA

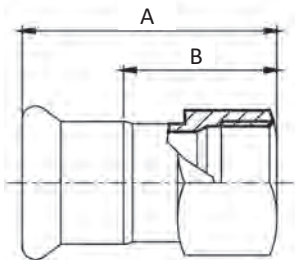

Pipe Size		Dimensions		Weight lbs kg
Nominal in mm	O.D. in mm	A in mm	B in mm	
<b>1/2 x 1/2</b> 15 x 15	<b>0.84 x 0.84</b> 21 x 21	<b>2.2</b> 55	<b>1.3</b> 34	<b>0.20</b> 0.1
<b>1/2 x 3/4</b> 15 x 20	<b>0.84 x 1.05</b> 21 x 27	<b>2.4</b> 62	<b>1.6</b> 41	<b>0.28</b> 0.1
<b>1/2 x 1</b> 15 x 25	<b>0.84 x 1.32</b> 21 x 33	<b>2.6</b> 65	<b>1.7</b> 44	<b>0.43</b> 0.2
<b>3/4 x 1/2</b> 20 x 15	<b>1.05 x 0.84</b> 26.7 x 21	<b>2.5</b> 63	<b>1.5</b> 39	<b>0.32</b> 0.2
<b>3/4 x 3/4</b> 20 x 20	<b>1.05 x 1.05</b> 27 x 27	<b>2.5</b> 63	<b>1.5</b> 39	<b>0.28</b> 0.1
<b>3/4 x 1</b> 20 x 25	<b>1.05 x 1.32</b> 27 x 33	<b>2.6</b> 66	<b>1.6</b> 42	<b>0.43</b> 0.2
<b>1 x 1/2</b> 25 x 15	<b>1.32 x 0.84</b> 33 x 21	<b>2.6</b> 65	<b>1.5</b> 39	<b>0.50</b> 0.2
<b>1 x 3/4</b> 25 x 20	<b>1.32 x 0.84</b> 33 x 21	<b>2.6</b> 65	<b>1.5</b> 39	<b>0.43</b> 0.2
<b>1 x 1</b> 25 x 25	<b>1.32 x 1.32</b> 33 x 33	<b>2.6</b> 65	<b>1.5</b> 39	<b>0.43</b> 0.2
<b>1 x 1-1/2</b> 25 x 40	<b>1.32 x 1.90</b> 33 x 48	<b>3.1</b> 80	<b>2.1</b> 54	<b>0.80</b> 0.4
<b>1-1/2 x 1</b> 40 x 25	<b>1.90 x 1.32</b> 48 x 33	<b>3.1</b> 78	<b>1.9</b> 47	<b>1.26</b> 0.6
<b>1-1/2 x 1-1/2</b> 40 x 40	<b>1.90 x 1.90</b> 48 x 48	<b>3.1</b> 77	<b>1.9</b> 47	<b>0.64</b> 0.3
<b>1-1/2 x 2</b> 40 x 50	<b>1.90 x 2.38</b> 48 x 60	<b>3.7</b> 93	<b>2.5</b> 62	<b>1.21</b> 0.5
<b>2 x 1-1/2</b> 50 x 40	<b>2.38 x 1.90</b> 60 x 48	<b>3.9</b> 99	<b>2.1</b> 54	<b>1.83</b> 0.8
<b>2 x 2</b> 50 x 50	<b>2.38 x 2.38</b> 60 x 60	<b>3.9</b> 100	<b>2.2</b> 55	<b>1.04</b> 0.5



Certified to  
NSF/ANSI 61-G



# Stainless Steel Press Male Adaptor

PJEMA

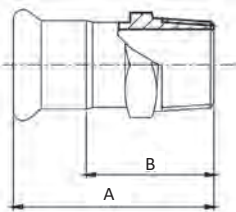

Pipe Size		Dimensions		Weight lbs kg
Nominal in mm	O.D. in mm	A in mm	B in mm	
<b>1/2 x 1/2</b> 15 x 15	<b>0.84 x 0.84</b> 21 x 21	<b>2.2</b> 56	<b>1.4</b> 35	<b>0.15</b> 0.1
<b>1/2 x 3/4</b> 15 x 20	<b>0.84 x 1.05</b> 21 x 27	<b>2.3</b> 58	<b>1.5</b> 37	<b>0.20</b> 0.1
<b>1/2 x 1</b> 15 x 25	<b>0.84 x 1.32</b> 21 x 33	<b>2.4</b> 62	<b>1.6</b> 41	<b>0.34</b> 0.2
<b>3/4 x 1/2</b> 20 x 15	<b>1.05 x 0.84</b> 27 x 21	<b>2.4</b> 60	<b>1.4</b> 36	<b>0.22</b> 0.1
<b>3/4 x 3/4</b> 20 x 20	<b>1.05 x 1.05</b> 27 x 27	<b>2.4</b> 62	<b>1.5</b> 38	<b>0.21</b> 0.1
<b>3/4 x 1</b> 20 x 25	<b>1.05 x 1.32</b> 27 x 33	<b>2.6</b> 65	<b>1.6</b> 41	<b>0.29</b> 0.1
<b>1 x 3/4</b> 25 x 20	<b>1.32 x 1.05</b> 33 x 27	<b>2.5</b> 64	<b>1.5</b> 38	<b>0.28</b> 0.1
<b>1 x 1</b> 25 x 25	<b>1.32 x 1.32</b> 33 x 33	<b>2.6</b> 67	<b>1.6</b> 41	<b>0.32</b> 0.3
<b>1 x 1-1/2</b> 25 x 40	<b>1.32 x 1.90</b> 33 x 48	<b>2.7</b> 70	<b>1.7</b> 44	<b>0.58</b> 0.3
<b>1-1/2 x 3/4</b> 40 x 20	<b>1.90 x 1.05</b> 48 x 27	<b>2.8</b> 71	<b>1.6</b> 40	<b>0.55</b> 0.3
<b>1-1/2 x 1</b> 40 x 25	<b>1.90 x 1.32</b> 48 x 33	<b>2.9</b> 74	<b>1.7</b> 43	<b>0.62</b> 0.3
<b>1-1/2 x 1-1/2</b> 40 x 40	<b>1.90 x 1.90</b> 48 x 48	<b>2.9</b> 74	<b>1.7</b> 44	<b>0.64</b> 0.3
<b>2 x 1-1/2</b> 50 x 40	<b>2.38 x 1.90</b> 60 x 48	<b>3.5</b> 88	<b>1.7</b> 43	<b>0.94</b> 0.4
<b>2 x 2</b> 50 x 50	<b>2.38 x 2.38</b> 60 x 60	<b>3.8</b> 96	<b>2.0</b> 51	<b>1.04</b> 0.5



Certified to  
NSF/ANSI 61-G



# Stainless Steel Press Flange

PJEF

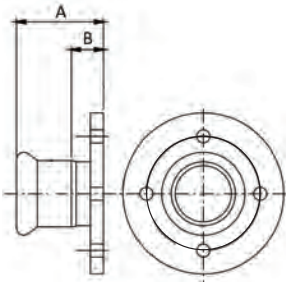

Pipe Size		Dimensions		Weight lbs kg
Nominal in mm	O.D. in mm	A in mm	B in mm	
1/2	0.840	1.9	1.0	0.84
15	21	47	26	0.4
3/4	1.050	2.2	1.3	1.28
20	27	56	32	0.6
1	1.315	2.5	1.5	1.77
25	33	64	38	0.8
1-1/2	1.900	3.4	2.2	2.90
40	48	87	56	1.3
2	2.375	4.7	2.9	4.65
50	60	120	75	2.1

# Stainless Steel Press Cap

PJEP

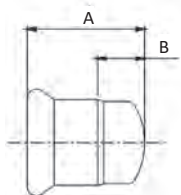

Pipe Size		Dimensions		Weight lbs kg
Nominal in mm	O.D. in mm	A in mm	B in mm	
1/2	0.840	1.7	0.9	0.09
15	21	43	22	0.1
3/4	1.050	1.7	0.8	0.13
20	267	43	19	0.1
1	1.315	1.9	0.8	0.18
25	33	47	21	0.1
1-1/2	1.900	2.2	1.0	0.33
40	48	55	24	0.1
2	2.375	2.9	1.1	0.55
50	60	73	28	0.2



Certified to  
NSF/ANSI 61-G



# Stainless Steel Press Union

PJEU

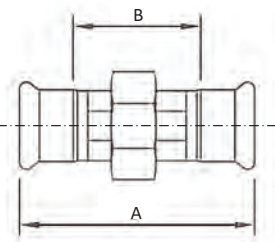

Pipe Size		Dimensions		Weight lbs kg
Nominal in mm	O.D. in mm	A in mm	B in mm	
1/2	0.840	3.9	2.3	0.62
15	21	100	58	0.3
3/4	1.050	4.5	2.6	0.82
20	27	115	67	0.4
1	1.315	4.8	2.7	0.97
25	33	121	69	0.4
1-1/2	1.900	6.3	3.9	2.36
40	48	160	99	1.1
2	2.375	8.3	4.7	3.70
50	60	210	120	1.7

# Stainless Steel Press Van Stone Flange

PJEVF

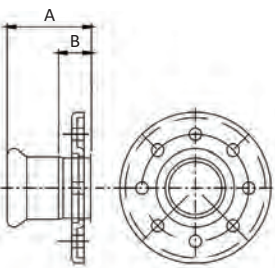

Pipe Size		Dimensions		Weight lbs kg
Nominal in mm	O.D. in mm	A in mm	B in mm	
1/2	0.840	3.1	2.2	0.95
15	21	78	57	0.4
3/4	1.050	3.2	2.2	1.39
20	27	81	57	0.6
1	1.315	3.3	2.2	1.84
25	33	83	57	0.8
1-1/2	1.900	3.5	2.2	2.98
40	48	88	57	1.4
2	2.375	4.5	2.8	4.79
50	60	115	70	2.2



Certified to  
NSF/ANSI 61-G





# Stainless Steel Press Weld Adaptor

PJEWA

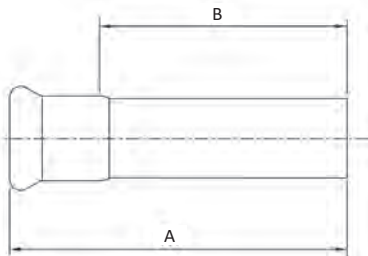

Pipe Size		Dimensions		Weight lbs kg
Nominal in mm	O.D. in mm	A in mm	B in mm	
<b>1/2</b> 15	<b>0.840</b> 21	<b>5.1</b> 130	<b>4.0</b> 102	<b>0.25</b> 0.1
<b>3/4</b> 20	<b>1.050</b> 27	<b>5.3</b> 134	<b>4.0</b> 102	<b>0.33</b> 0.2
<b>1</b> 25	<b>1.315</b> 33	<b>5.3</b> 136	<b>4.0</b> 102	<b>0.42</b> 0.2
<b>1-1/2</b> 40	<b>1.900</b> 48	<b>5.5</b> 140	<b>4.0</b> 102	<b>0.65</b> 0.3
<b>2</b> 50	<b>2.375</b> 60	<b>6.1</b> 155	<b>4.0</b> 102	<b>0.92</b> 0.4



Certified to  
NSF/ANSI 61-G



# M18™ Force Logic Press Tool



## M18™ FORCE LOGIC™ Long Throw Press Tool 1/2"-1" SS Kit

Designed to press GroovJoint stainless steel press fittings onto sch. 5 or sch. 10 pipe. An adjustable stroke length delivers optimized cycle time on 1/2"-2" stainless steel press connections. The press tool's in-line design offers unrivaled access for navigating around installed pipes, while also delivering on the highest level of press accuracy and reliability, the cordless press tool will operate 50,000 cycles before calibration is needed, delivering the longest calibration interval in the industry and keeping the tool on the job to maximize your return on investment.



1/2": 49-16-2650S



3/4": 49-16-2651S



1": 49-16-2652S

## 1-1/2"-2" IPS Ring Kit

Needed to press fittings 1-1/2 and 2" with the M18™ FORCE LOGIC™ Long Throw Press Tool. 2-hinge design 1-1/2" and 2" jaws require the ring adapter jaw to press fittings.



1-1/2": 49-16-2655S



2": 49-16-2654S



Ring Jaw: 49-16-2659S

### Specifications

<b>Voltage</b>	18V	<b>Weight</b>	10.1 lbs.
<b>Battery</b>	M18™ REDLITHIUM™	<b>Width</b>	4.8"
<b>Charger</b>	M18™ and M12™ Multi-Voltage Charger	<b>Force</b>	7,200 lbs.
<b>Tool Warranty</b>	5 years	<b>Jaw Warranty</b>	2 years
<b>Battery Warranty</b>	3 years	<b>Jaw Capacity</b>	1/2" – 2" SS Fitting
<b>Length</b>	20.1"	<b>Approximate Cycle Time</b>	5 seconds and 10 seconds at full stroke

*This tool is the only tool authorized by GroovJoint to be used with the GroovJoint press system.*

GroovJoint reserves the right to change the contents without notice.

# TUF-LUBE™ Grooved Coupling Gasket Grease

Tuf-Lube is a mixed fatty acid soap dispersed in glycols and water solvents with a clay pigment filler.

It resists evaporation and will not freeze.

Mating of abutting pipes forces the gel into the cavity, thus providing the needed lubrication to complete coupling and seal the joint.

The soap lubricant does not dry out when gaskets are stored in sealed plastic containers or bags.



- Tuf Lube maintains its soft paste consistency and amber/tan color.
- Can be used from -10°F to 150°F.
- Can be used on all types of pipe including asbestos cement, cast iron, concrete, plastic and clay pipe.
- Will not deteriorate natural rubber, synthetic rubber or plastic gaskets.
- Tuf-Lube is certified to meet NSF code 61 standards for potable water system uses.
- Strict analytical standards and formula consistency are used to assure production of a safe lubricant for water pipe joining needs.
- Environmentally friendly raw materials common in the soap and lubricants industry are used in producing Tuf-Lube.
- Will not irritate the hands and is not toxic.
- Contains no petroleum oils or phosphates.
- Contains no silicone.
- Manufactured in the USA.
- VOC Content: Minimal (2%)
- Available in 1 quart tub (#1010031) and 55-gallon drum (#1010033).

The information contained herein is produced in good faith and is believed to be reliable but is for guidance only. GroovJoint cannot assume liability or responsibility for results obtained in the use of its product by persons whose methods are outside or beyond our control. It is the user's responsibility to determine the suitability of any of the products, methods of use, or preparation prior to use, mentioned in our literature. It is the user's responsibility to observe and adapt such precautions as may be advisable for the protection of personnel and property in the handling and use of any of our products.

Appearance (neat)	Soft Amber Paste/Bland Odor
ph (1%)	9.5
Bulk Density	9.3 lb/gal
Free Fatty Acid	1-3%
Total Alkalinity	100 mg KOH/g equivalent
Penetration	300-350 1/10mm @ 77°F 200-250 1/10mm @ 0°F

## Data Sheets

Data Sheets are available upon request or via [www.groovjoint.com](http://www.groovjoint.com).

## Terms & Conditions of Sale

These terms and conditions shall apply to any purchase order or sales of GroovJoint products.

No alteration, modification or waiver of these terms and conditions whether on Customer's purchase order or otherwise shall be valid unless the alteration, modification or waiver is specifically accepted in writing by an authorized representative of GroovJoint.

**TERMS OF PAYMENT:** As stated on invoice.

**MINIMUM INVOICE CHARGES:** \$50.00 for any single order.

**RETURNS:** Orders cannot be canceled without written authorization. No material can be returned without our written approval. Restocking fees may apply.

**SHIPPING TERMS:** F.O.B. shipping point- freight prepaid and allowed on single orders having a net price value of \$9,000 or more, for shipment at one time to one destination, as determined by GroovJoint within the continental United States, excluding Alaska, Hawaii, Puerto Rico and U.S. possessions.

Shipping on orders less than net price value of \$9,000, F.O.B. shipping point will be paid by the customer. The cost of any special packaging or handling that has been requested by the customer, and is not part of our normal handling methods, will be added to the order and paid by the customer.

GroovJoint will make every effort to ship by the scheduled delivery date but reserves the right to ship within a reasonable period thereafter. GroovJoint shall not be held liable for any kind of damages, including but not limited to incidental or consequential damages for lost revenue or lost sales or liquidated damages, directly or indirectly arising from delays or failure to meet shipping dates.

Orders, when accepted, cannot be canceled without our written consent. No material will be taken back without our written consent. Orders for non-standard (i.e. non-cancellable/non-returnable) material may not be canceled nor will GroovJoint accept return of such material for credit.

Claims for corrections must be made within 10 days of receipt of goods. Carriers are responsible for goods lost, damaged or delayed in transit. For your own protection, have Transportation Company's agent verify damages, shortages or delays and note them on freight bill.

**WARRANTY:** We warrant all products to be free from defects in materials and workmanship under normal conditions of use and service. Our obligation under this warranty is limited to repairing or replacing at our option at our factory any product which shall within one year after delivery to original buyer be returned with transportation charges prepaid, and which our examination shall show to our satisfaction to have been defective.

This warranty is made expressly in lieu of any other warranties, express or implied, including any implied warranty of merchantability or fitness for a particular purpose. The buyer's sole and exclusive remedy shall be for the repair or replacement of defective products as provided herein. The buyer agrees that no other remedy (including, but not limited to, incidental or consequential damages for lost profits, lost sales, injury to person or property or any other incidental or consequential loss) shall be available to him.

GroovJoint neither assumes nor authorizes any person to assume for it any other liability in connection with the sale of such products.

**This warranty shall not apply to any product which has been subject to negligence, misuse, or accident, which has been repaired or altered in any manner outside of GroovJoint's facilities or which has been used in a manner contradictory to GroovJoint's instructions or recommendations. GroovJoint shall not be responsible for design errors due to inaccurate or incomplete information supplied by Buyer or its representatives.**

# Notes



**Corporate Office:**

155 North Wacker Drive  
Suite 4250

Chicago, IL 60606

312-803-2627

[sales@groovjoint.com](mailto:sales@groovjoint.com)

[www.groovjoint.com](http://www.groovjoint.com)

